



Board of Directors

Brian Brennan, Director
Richard Hajas, Director
Neil Cole, Director

Mary Bergen, Director
Pete Kaiser, Director

CASITAS MUNICIPAL WATER DISTRICT

Meeting to be held at the
1055 Ventura Ave.
Oak View, CA 93022

The meeting will also be held virtually via Zoom.

Join Zoom Meeting

<https://us06web.zoom.us/j/91094478837?pwd=VnNOQTZyQVlk4K2pnaWpjYVI1TkpRdz09>

Meeting ID: 910 9447 8837

Passcode: 736519

To join the meeting via teleconference please call (888) 788-0099 or (877) 853-5247

Enter Meeting ID: 910 9447 8837# Passcode: 736519#

July 13, 2022 @ 5:00 PM

Right to be heard: Members of the public have a right to address the Board directly on any item of interest to the public which is within the subject matter jurisdiction of the Board. The request to be heard should be made immediately before the Board's consideration of the item. No action shall be taken on any item not appearing on the agenda unless the action is otherwise authorized by subdivision (b) of §54954.2 of the Government Code and except that members of a legislative body or its staff may briefly respond to statements made or questions posed by persons exercising their public testimony rights under section 54954.3 of the Government Code.

Special Accommodations: If you require special accommodations for attendance at or participation in this meeting, please notify our office 24 hours in advance at (805) 649-2251, ext. 113. (Govt. Code Section 54954.1 and 54954.2(a)).

1. CALL TO ORDER
2. ROLL CALL
3. PLEDGE OF ALLEGIANCE

4. AGENDA CONFIRMATION
5. PUBLIC COMMENTS - Presentation on District related items that are not on the agenda - three minute limit.
6. CONSENT AGENDA
 - 6.a. Accounts Payable Report
[Accounts Payable Report.pdf](#)
 - 6.b. Minutes of the June 22, 2022 Board Meeting.
[6 22 2022 Min.pdf](#)
 - 6.c. Resolution proclaiming a local emergency persists, re-ratifying the proclamation of a state of emergency by Executive Order and re-authorizing remote teleconference meetings of the legislative bodies of Casitas Municipal Water District for the period of July 13, 2022 to August 12, 2022 pursuant to Brown Act provisions.
[Resolution Subsequent AB 361.pdf](#)
7. ACTION ITEMS
 - 7.a. Approve Change Order No. 4 to Travis Agricultural Construction, Inc. for the Mutual Well #7 Well Equipment and Site Work, Specification No. 20-438 in the amount of \$12,565.35.
[Board Memo for Mutual Well 7 Well Equipment and Site Work Change Order 4 \(2\).pdf](#)
 - 7.b. Approve Amendment to Rincon Consultants for preparation of the Initial Study/Mitigated Negative Declaration for the Ventura County - Santa Barbara Intertie project with a time extension to June 30, 2023 and an amendment request in the not to exceed amount of \$24,158.00 for a revised contract amount of \$267,886.00.
[Board Memo Amendment.pdf](#)
 - 7.c. Consideration and possible action on a term sheet from United Water Conservation District regarding a five-year transfer of Casitas MWD's State Water Project Table A water supply.
[Board Memo for United Draft Term Sheet 071322.pdf](#)
[Casitas-United Draft Transfer Term Sheet 071322.pdf](#)
 - 7.d. Approval of an application from Granite Construction Inc. for a temporary water service for the purposes of a concrete batch plant water supply for the State of California's Highway 101 improvement project.
[Board Memo Granite Const Temp Application 071322.pdf](#)
[Granite Const Application for Temp Service 071322 ATT1.pdf](#)
 - 7.e. Approval of an application from Security Paving Company, Inc. for a temporary water service for the purposes of a construction water supply for the State of California's Highway 33/San Antonio Bridge improvement project.
[Board Memo Security Paving Temp Application 071322.pdf](#)

[Security Paving HWY 33 Project Temp App 071322.pdf](#)

- 7.f. Consideration of the claims of Antar and Jennifer Ron in the amount of \$250 for their deductible and \$513.59 for lodging.
[Ltr re Claims of Jennifer and Antar Ron.pdf](#)
[Claim of Antar and Jennifer Ron Deductible.pdf](#)
[Claim of Jennifer and Antar Ron Lodging.pdf](#)

8. INFORMATION ITEMS

- 8.a. Finance Committee Minutes.
[Finance Minutes 061722.pdf](#)
- 8.b. State Water Project Intertie Report.
[SWP Intertie Project Cost 6-30-22.pdf](#)
- 8.c. CFD 2013-01 Project Cost Report
[CFD 2013-1 Project Cost 6-30-2022.pdf](#)
- 8.d. Adjudication Charges Report.
[Adjudication Charges YTD 6.30.22.pdf](#)
- 8.e. Financial Statements for April 2022.
[Financial Statements 04-30-2022 Summary.pdf](#)
- 8.f. Non-Budgeted Items Log.
[Non-Budgeted Items Log.pdf](#)
- 8.g. Investment Report.
[Investment Report 6.30.2022.pdf](#)

9. GENERAL MANAGER COMMENTS

10. BOARD OF DIRECTOR REPORTS ON MEETINGS ATTENDED

11. BOARD OF DIRECTOR COMMENTS PER GOVERNMENT CODE SECTION 54954.2(a).

12. CLOSED SESSION

- 12.a. CONFERENCE WITH LEGAL COUNSEL – EXISTING LITIGATION (Government Code Section 54956.9(a) Santa Barbara Channelkeeper v. State Water Resources Control Board, City of San Buenaventura, et al.; and City of San Buenaventura v Duncan Abbott, et al., Cross Complaint; Superior Court of the State of California, County of Los Angeles, Case No. 19STCP01176.

13. ADJOURNMENT

CASITAS MUNICIPAL WATER DISTRICT
General Fund Check Authorization
Checks Dated 06/16/22 - 07/06/22
Presented to the Board of Directors For Approval July 13, 2022

Check	Payee	Description	Amount
001132	Payables Fund Account # 9759651478	Accounts Payable Batch 062222	\$ 1,385,313.58
001133	Payables Fund Account # 9759651478	Accounts Payable Batch 062922	\$ 354,705.46
001135	Payables Fund Account # 9759651478	Accounts Payable Batch 070622	\$ 474,620.09
			<u>\$ 2,214,639.13</u>
001134	Payroll Found Account # 9469730919	Estimated Payroll 07/28/22	\$ 260,000.00
		Total	<u><u>\$ 2,474,639.13</u></u>

Publication of check register is in compliance with Section 53065.6 of the Government Code which requires the District to disclose reimbursements to employees and/or directors.

The above numbered checks, 001132-001135 have been duly audited is hereby certified as correct.



 Janyne Brown, Chief Financial Officer

A/P Fund

Publication of check register is in compliance with Section 53065.6 of the Government Code which requires the District to disclose reimbursements to employees and/or directors.

001132 A/P Checks: 046827-46872
A/P Draft 000347
046858 - Meiners Oaks ACE hardware - Continuation of detail of check 046857

001133 A/P Checks: 046873-046928
A/P Draft 000348-000354
Voids:
046921 - Wai & Connor LLP - Continuation of detail of check 046920
046922 - Wai & Connor LLP - Continuation of detail of check 046920
046923 - Wai & Connor LLP - Continuation of detail of check 046920

001135 A/P Checks: 046929-46992
A/P Draft 000355-000357
Voids:
046958 - Meiners Oaks Ace Hardware - Continuation of detail of check 046957



Janyne Brown , Chief Financial Officer

CERTIFICATION

Payroll disbursements for the pay period ending 06/25/22
Pay Date 06/30/22
have been duly audited and are
hereby certified as correct.

Signed: Jayne Brown

Jayne Brown

VENDOR I.D.	NAME	STATUS	CHECK DATE	INVOICE AMOUNT	DISCOUNT	CHECK NO	CHECK STATUS	CHECK AMOUNT
C-CHECK	VOID CHECK	V	6/22/2022			046858		
C-CHECK	VOID CHECK	V	6/29/2022			046921		
C-CHECK	VOID CHECK	V	6/29/2022			046922		
C-CHECK	VOID CHECK	V	6/29/2022			046923		
C-CHECK	VOID CHECK	V	7/06/2022			046958		

* * T O T A L S * *	NO	INVOICE AMOUNT	DISCOUNTS	CHECK AMOUNT
REGULAR CHECKS:	0	0.00	0.00	0.00
HAND CHECKS:	0	0.00	0.00	0.00
DRAFTS:	0	0.00	0.00	0.00
EFT:	0	0.00	0.00	0.00
NON CHECKS:	0	0.00	0.00	0.00
VOID CHECKS:	5	VOID DEBITS 0.00		
		VOID CREDITS 0.00	0.00	0.00

TOTAL ERRORS: 0

VENDOR SET: 01 BANK:	TOTALS:	NO	INVOICE AMOUNT	DISCOUNTS	CHECK AMOUNT
		5	0.00	0.00	0.00
BANK:	TOTALS:	5	0.00	0.00	0.00

VENDOR I.D.	NAME	STATUS	CHECK DATE	INVOICE AMOUNT	DISCOUNT	CHECK NO	CHECK STATUS	CHECK AMOUNT
05939	Health Equity I-INV3893886 Reimburse Med/Dep Care	D	6/22/2022	118.50		000347		118.50
05939	Health Equity I-INV3917644 Monthly Compliance Fee	D	6/29/2022	175.00		000348		
	I-INV3931844 Reimburse Med/Dep Care	D	6/29/2022	255.83		000348		430.83
00131	JCI JONES CHEMICALS, INC I-889094 Chlorine - TP, CM 889155	D	6/29/2022	3,999.36		000349		3,999.36
00128	INTERNAL REVENUE SERVICE I-T1 202206271993 Federal Withholding	D	6/29/2022	42,882.65		000350		
	I-T1 202206291995 Federal Withholding	D	6/29/2022	338.73		000350		
	I-T3 202206271993 SS Withholding	D	6/29/2022	46,275.76		000350		
	I-T3 202206291995 SS Withholding	D	6/29/2022	347.70		000350		
	I-T4 202206271993 Medicare Withholding	D	6/29/2022	10,822.60		000350		
	I-T4 202206291995 Medicare Withholding	D	6/29/2022	81.32		000350		100,748.76
00187	CALPERS I-PBB202206271993 PERS BUY BACK	D	6/29/2022	130.46		000351		
	I-PBP202206271993 PERS BUY BACK	D	6/29/2022	161.96		000351		
	I-PEB202206271993 PEPRA EMPLOYEES PORTION	D	6/29/2022	12,263.26		000351		
	I-PEM202206271993 PERS EMPLOYEE PORTION MGMT	D	6/29/2022	1,774.91		000351		
	I-PER202206271993 PERS EMPLOYEE PORTION	D	6/29/2022	7,186.22		000351		
	I-PRB202206271993 PEBRA EMPLOYER PORTION	D	6/29/2022	13,789.38		000351		
	I-PRR202206271993 PERS EMPLOYER PORTION	D	6/29/2022	11,838.27		000351		47,144.46
00180	S.E.I.U. - LOCAL 721 I-COP202206271993 SEIU 721 COPE	D	6/29/2022	12.50		000352		
	I-UND202206271993 UNION DUES	D	6/29/2022	922.75		000352		935.25
00049	STATE OF CALIFORNIA I-T2 202206271993 STATE WITHHOLDING (CA)	D	6/29/2022	16,416.14		000353		
	I-T2 202206291995 STATE WITHHOLDING (CA)	D	6/29/2022	141.13		000353		16,557.27
05790	STATE OF OREGON I-OST202206271993 OR STATE TRANSIT TAX	D	6/29/2022	5.58		000354		
	I-T2 202206271993 STATE WITHHOLDING (OR)	D	6/29/2022	410.09		000354		415.67
05939	Health Equity I-INV3949672 Reimburse Med/Dep Care	D	7/06/2022	382.17		000355		382.17
05973	Mechanics Bank Credit Card I-062722a Two-Tone Vest - ENG	D	7/06/2022	80.81		000356		80.81

VENDOR I.D.	NAME	STATUS	CHECK DATE	INVOICE AMOUNT	DISCOUNT	CHECK NO	CHECK STATUS	CHECK AMOUNT
03206 I-6567750	U.S. Bank Global Corporate Tru CFD 2013-1 Ojai Tax Bond	D	7/06/2022	3,025.00		000357		3,025.00
02587 I-51960	A&M LAWNMOWER SHOP Gas Powered Tools - MAINT	R	6/22/2022	1,247.04		046827		1,247.04
00004 I-0687586	ACWA JOINT POWERS INSURANCE AU Health Insurance 07/22	R	6/22/2022	169,778.61		046828		169,778.61
00026 I-100602	AERA ENERGY LLC Cathodic Protection FY22-23	R	6/22/2022	200.00		046829		200.00
00784 I-IN1013674 I-IN1013920 I-IN1016982	AM Conservation Group, Inc. BT Aerator - PR Shower Control Valve - PR Hose Nozzle - PR	R R R	6/22/2022 6/22/2022 6/22/2022	402.09 566.96 412.67		046830 046830 046830		1,381.72
03044 C-1T13-4M3W-6416 I-17CC-MDQV-96HX I-1GNJ-1W9C-1DJ6 I-1QDL-L9QX-4TDX	Amazon Capital Services Coffee CR - MGMT Internal Solid State Drives-TP Cradlepoint Replacement - TP Coffee - MGMT	R R R R	6/22/2022 6/22/2022 6/22/2022 6/22/2022	171.18CR 62.96 122.05 171.18		046831 046831 046831 046831		185.01
00836 I-22430063	AMERICAN RED CROSS Lifeguarding Training - WP	R	6/22/2022	427.50		046832		427.50
00014 I-SI1937456 I-SI1940596 I-SI1940607	AQUA-FLO SUPPLY Fittings - WP Couplings & 90 Ell - LCRA Valve - LCRA	R R R	6/22/2022 6/22/2022 6/22/2022	179.02 22.65 139.06		046833 046833 046833		340.73
03429 I-4219431709	AT&T Acct#8310009376326	R	6/22/2022	1,287.10		046834		1,287.10
03429 I-9703021701	AT&T Acct#8310009376372	R	6/22/2022	1,287.10		046835		1,287.10
03021 I-000025-491-561	Central Communications Call Center 05/22	R	6/22/2022	192.50		046836		192.50
02339 I-55989	Clark Engineering Construction San Antonio Vessel Walkway - E	R	6/22/2022	11,144.00		046837		11,144.00

VENDOR I.D.	NAME	STATUS	CHECK DATE	INVOICE AMOUNT	DISCOUNT	CHECK NO	CHECK STATUS	CHECK AMOUNT
00752	COLE-PARMER INSTRUMENT CO. I-3147502 Micropipette & Supplies - LAB	R	6/22/2022	122.54		046838		122.54
00662	Diamond A Equipment I-A01223003100 Case Backhoe - Unit 121	R	6/22/2022	260.75		046839		260.75
00086	E.J. Harrison & Sons Inc I-10216 Acct#1C00053370	R	6/22/2022	285.36		046840		285.36
00086	E.J. Harrison & Sons Inc I-10234 Acct#1C00054240	R	6/22/2022	446.23		046841		446.23
00086	E.J. Harrison & Sons Inc I-5414 Acct#102258843	R	6/22/2022	307.85		046842		307.85
03425	Eagle Aerial Solutions I-20458 LAM Data Review - PR	R	6/22/2022	3,000.00		046843		3,000.00
10229	FENCE FACTORY - VENTURA I-694146 Fence Rental - WP	R	6/22/2022	1,045.00		046844		1,045.00
00099	FGL ENVIRONMENTAL I-207316A THM/HAA Monitoring 05/03/22	R	6/22/2022	870.00		046845		
	I-207319A OWS-San Antonio TP 05/03/22	R	6/22/2022	32.00		046845		
	I-207816A OWS Nitrate Monitoring 051022	R	6/22/2022	19.00		046845		921.00
05962	First on Scene Training LLC I-91436-A Fork Lift Training - ADM/EM/PL	R	6/22/2022	1,440.00		046846		1,440.00
00106	FRONTIER PAINT I-F0284042 Paint - WP	R	6/22/2022	230.37		046847		230.37
00115	GRAINGER, INC I-9344683538 Pneumatic Wheel - PL	R	6/22/2022	130.61		046848		130.61
01052	HARBOR FREIGHT TOOLS USA, INC I-985465 Paint Brush - LCRA	R	6/22/2022	22.50		046849		22.50
05849	Hill Brothers Chemical Co I-07134882 Liquid Ammonia Sulfate - TP	R	6/22/2022	883.17		046850		883.17
00596	HOME DEPOT C-9900985 White Plastic CR - MAINT	R	6/22/2022	258.33CR		046851		
	I-473352 White Plastic -- MAINT	R	6/22/2022	258.33		046851		
	I-4900328 Dewalt Battery Pack - MAINT	R	6/22/2022	337.58		046851		337.58

VENDOR I.D.	NAME	STATUS	CHECK DATE	INVOICE AMOUNT	DISCOUNT	CHECK NO	CHECK STATUS	CHECK AMOUNT
05799	Jack Henry & Associates Inc.							
I-3981783	RemitPlus Software Maintenance	R	6/22/2022	1,915.68		046852		1,915.68
00667	Kennedy/Jenks Consultants, Inc							
I-155655	Grant Support - ENG	R	6/22/2022	1,515.00		046853		1,515.00
04803	Angie Lopez							
I-1052126	Camping Cancellation - LCRA	R	6/22/2022	194.00		046854		194.00
02215	Scott MacDonald							
I-061522	Reimburse Expenses 06/22	R	6/22/2022	169.53		046855		169.53
00145	MAGNUM FENCE & SECURITY, INC.							
I-14342	Replace Gate at Miramonte - MA	R	6/22/2022	3,932.00		046856		3,932.00
00151	MEINERS OAKS ACE HARDWARE							
I-008027	Fittings - LCRA	R	6/22/2022	9.35		046857		
I-008262	Mini Mats & Cement - LCRA	R	6/22/2022	93.23		046857		
I-008267	Cleaning Supplies - LCRA	R	6/22/2022	11.11		046857		
I-008431	Bolts & Screws - LCRA	R	6/22/2022	22.20		046857		
I-008447	Tie Down, Bolts & Screws - LAB	R	6/22/2022	59.34		046857		
I-008804	Concrete Mix - WP	R	6/22/2022	31.95		046857		
I-008807	Sprypaint - UT	R	6/22/2022	21.44		046857		
I-009085	Single Cut Key - MAINT	R	6/22/2022	1.94		046857		
I-009196	Cutter, Measure Tape, Tester	R	6/22/2022	132.24		046857		
I-009197	Paint Brush, Roller & Tape -TP	R	6/22/2022	143.92		046857		
I-009198	Knife, Wire Brush & Hose - TP	R	6/22/2022	63.72		046857		
I-009204	Wrench & Postholetamper - UT	R	6/22/2022	140.79		046857		
I-009305	Pliers - EM	R	6/22/2022	16.58		046857		747.81
01570	Ojai Auto Supply							
C-546143	Flasher - Unit 55	R	6/22/2022	32.43CR		046859		
C-546191	Core Deposit - Unit 16	R	6/22/2022	0.90CR		046859		
I-544730	V Belt - LCRA	R	6/22/2022	61.30		046859		
I-545738	Flasher - Unit 55	R	6/22/2022	16.22		046859		
I-545755	Flasher - Unit 55	R	6/22/2022	0.64		046859		
I-546018	Flasher - Unit 55	R	6/22/2022	16.22		046859		
I-546067	Door Weatherstrip - Unit 55	R	6/22/2022	52.66		046859		
I-546148	Alternator - Unit 16	R	6/22/2022	168.69		046859		282.40
00168	OJAI VALLEY NEWS							
I-1956	Ad 05/20/22	R	6/22/2022	150.00		046860		
I-2129	Legal Notice 06/10/22-06/17/22	R	6/22/2022	40.50		046860		
I-2137	Ad 06/10/22	R	6/22/2022	431.00		046860		621.50

VENDOR I.D.	NAME	STATUS	CHECK DATE	INVOICE AMOUNT	DISCOUNT	CHECK NO	CHECK STATUS	CHECK AMOUNT
05713	Pops Auto Repair							
I-0235	Window Tint - Unit 59	R	6/22/2022	220.00		046861		
I-0236	Window Tint - Unit 14	R	6/22/2022	220.00		046861		440.00
00790	PROFORMA							
I-BI85007175A	Hoodies, T-Shirts & Hats - PL	R	6/22/2022	3,297.62		046862		3,297.62
00306	Rincon Consultants, Inc.							
I-40085	VTA-Carp Intertie Service-ENG	R	6/22/2022	8,686.00		046863		
I-40088	Robles Prog. Permits - ENG	R	6/22/2022	825.00		046863		
I-40090	Ayers Creek Construction - ENG	R	6/22/2022	1,832.73		046863		
I-40092	Fairview Environmental - ENG	R	6/22/2022	12,483.10		046863		
I-40095	Ojai Ave Pipe Environ Support	R	6/22/2022	8,234.84		046863		32,061.67
01107	SAWYER PETROLEUM							
I-S143065	Diesel - LCRA	R	6/22/2022	4,048.96		046864		
I-S143066	Gas - LCRA	R	6/22/2022	3,705.43		046864		7,754.39
00215	SOUTHERN CALIFORNIA EDISON							
I-061522	Acct#700028645962	R	6/22/2022	120,938.56		046865		120,938.56
00048	STATE OF CALIFORNIA							
I-061722	State Water Plan Payment	R	6/22/2022	1,010,182.00		046866		1,010,182.00
01696	SUPERIOR MACHINE							
I-4884	Machine Nut - EM	R	6/22/2022	431.00		046867		431.00
02527	Traffic Technologies LLC							
I-41205	Traffic Signs - LCRA	R	6/22/2022	398.76		046868		398.76
05959	Union Materials Testing, Inc.							
I-15	Slurry Backfill Coring - PL	R	6/22/2022	2,119.00		046869		2,119.00
00663	WAXIE SANITARY SUPPLY							
I-80973088	Hand Cleaner - LCRA	R	6/22/2022	75.51		046870		75.51
00270	Wells Fargo Bank							
I-061022a	Helment Assembly - TP	R	6/22/2022	634.38		046871		634.38
05932	Ghitterman Ghitterman & Feld F							
I-062222	1102WC180000001 06/11-06/24/22	R	6/22/2022	580.00		046872		580.00
01325	Aflac Worldwide Headquarters							
I-709390	Supplemental Insurance 06/22	R	6/29/2022	4,572.96		046873		4,572.96

VENDOR I.D.	NAME	STATUS	CHECK DATE	INVOICE AMOUNT	DISCOUNT	CHECK NO	CHECK STATUS	CHECK AMOUNT
05912	Aleshire & Wynder LLP							
I-67609	Metter #0001	R	6/29/2022	59.00		046874		59.00
03044	Amazon Capital Services							
C-1MYJ-JXTQ-7KMT	Toner Return - ADM	R	6/29/2022	75.08CR		046875		
I-11P6-LQYV-HL94	Hazard Sign - SAFE	R	6/29/2022	368.20		046875		
I-196G-T93L-Q6PR	Red Steel Safety Cans - MAINT	R	6/29/2022	368.66		046875		
I-1LQC-7Q44-39JC	Poison Ivy Relief - SAFE	R	6/29/2022	124.36		046875		
I-1T6K-TH1H-19XX	Impact Driver & Battery - TP	R	6/29/2022	442.07		046875		
I-1YR9-H1V3-6664	6 Port DIN Rail Switch - TP	R	6/29/2022	417.20		046875		1,645.41
01703	ARNOLD LAROCHELLE MATTHEWS							
I-5811a	Metter #5088-001	R	6/29/2022	4,256.00		046876		4,256.00
01666	AT & T							
I-000018395178	Acct#9391062398	R	6/29/2022	61.82		046877		61.82
01666	AT & T							
I-000018399794	Acct#9391064013	R	6/29/2022	25.04		046878		25.04
00030	B&R TOOL AND SUPPLY CO							
I-1900974293	Ear Plugs - LCRA	R	6/29/2022	299.55		046879		299.55
00036	BC TREE SERVICE, INC							
I-3916	Weed Abatement - MAINT	R	6/29/2022	2,700.00		046880		2,700.00
04111	Roadpost, Inc.							
I-BU01466495	Sat Phone Service - TP	R	6/29/2022	54.54		046881		54.54
03207	BMI PacWest Inc.							
I-18010	AC Maintenance - DO	R	6/29/2022	1,782.00		046882		
I-18399	Roble Control Room Heaters-ENG	R	6/29/2022	16,468.00		046882		
I-18550	Gorman Well P.M on A/C - MAINT	R	6/29/2022	530.50		046882		18,780.50
01843	COASTAL COPY							
I-1015996	Copier Usage - LCRA	R	6/29/2022	146.84		046883		146.84
02041	Custom Mailing Solutions, Inc							
I-9629	Mailing Ojai PL Postcard - ENG	R	6/29/2022	1,973.00		046884		1,973.00
05956	D.J.S. Special Inspections, In							
I-CW2201	Reinforced Concrete Inspection	R	6/29/2022	476.00		046885		476.00

VENDOR I.D.	NAME	STATUS	CHECK DATE	INVOICE AMOUNT	DISCOUNT	CHECK NO	CHECK STATUS	CHECK AMOUNT
00081	DELTA LIQUID ENERGY							
I-21611	Regulatory Recovery Fee	R	6/29/2022	6.19		046886		
I-21613	Propane - LCRA	R	6/29/2022	442.26		046886		448.45
00086	E.J. Harrison & Sons Inc							
I-10233	Acct#1C00054230	R	6/29/2022	3,751.32		046887		3,751.32
00086	E.J. Harrison & Sons Inc							
I-1688a	Acct#500546088	R	6/29/2022	2,484.14		046888		2,484.14
00395	Endress & Hauser Inc							
I-6002345908	Robles Radar Transducers - ENG	R	6/29/2022	2,776.56		046889		2,776.56
00095	FAMCON PIPE & SUPPLY							
I-S100077506.001	Hydrants - PL	R	6/29/2022	25,568.40		046890		
I-S100080579.001	Lever Weight - PL	R	6/29/2022	1,456.46		046890		
I-S100081321.001	Trenching Shovel - UT	R	6/29/2022	155.51		046890		27,180.37
00093	FEDERAL EXPRESS							
I-7-791-11795	Shipping - LAB	R	6/29/2022	33.68		046891		33.68
00099	FGL ENVIRONMENTAL							
I-208325A	Lab Water Quality 05/17/22	R	6/29/2022	55.00		046892		55.00
00115	GRAINGER, INC							
I-9321102973	Gloves - TP	R	6/29/2022	12.76		046893		12.76
00121	HACH COMPANY							
I-13089504	CHemkey Nitrite & Chlorine - T	R	6/29/2022	456.00		046894		
I-13101447	Mono-Chlor - TP	R	6/29/2022	1,047.45		046894		1,503.45
04022	Hamner, Jewell & Associates							
I-201748	Ventura-SB Row Srvs - ENG	R	6/29/2022	1,691.25		046895		
I-201777	ROW Service Skyhigh Drive -ENG	R	6/29/2022	437.50		046895		2,128.75
05746	Hasa Inc.							
I-824880	Chlorine for Ojai Sys. - TP	R	6/29/2022	861.37		046896		
I-824933	Chlorine for Ojai Sys. - TP	R	6/29/2022	3,042.78		046896		3,904.15
05879	Hogentogler & Co Inc							
I-0294474-IN	Thermo Conductivity Meter -LAB	R	6/29/2022	1,477.62		046897		1,477.62
00596	HOME DEPOT							
I-3113350	Tools & Materials for - TP	R	6/29/2022	1,352.37		046898		
I-3901807	Concrete - PL	R	6/29/2022	1,021.38		046898		2,373.75

VENDOR I.D.	NAME	STATUS	CHECK DATE	INVOICE AMOUNT	DISCOUNT	CHECK NO	CHECK STATUS	CHECK AMOUNT
00894	HOSE-MAN, INC. I-5296287-0001-05 Pump Hose - PL	R	6/29/2022	337.86		046899		337.86
00478	Layne Christensen Company I-2195340 Well MW6 Sand Test - ENG	R	6/29/2022	849.00		046900		849.00
02658	Liebert Cassidy Whitmore I-219334 Metter #CA182-00010	R	6/29/2022	1,560.00		046901		1,560.00
05966	Lynn C Johnson Associates I-062222 CMWD Demonstration Garden - PR	R	6/29/2022	3,435.00		046902		3,435.00
00329	MCMaster-CARR SUPPLY CO. I-80106329 Robles Diversion Winch - ENG	R	6/29/2022	2,782.30		046903		2,782.30
00151	MEINERS OAKS ACE HARDWARE							
	I-009248 Plug Draing Test - FISH	R	6/29/2022	8.77		046904		
	I-009366 Masonry Wheel - LCRA	R	6/29/2022	10.52		046904		
	I-009376 Disc 50Grit - LCRA	R	6/29/2022	16.38		046904		
	I-009524 Pipe PVC - FISH	R	6/29/2022	28.36		046904		
	I-009640 Flapper - LCRA	R	6/29/2022	7.80		046904		
	I-009841 Batteries - EM	R	6/29/2022	10.73		046904		
	I-009895 Bolts & Screws - LCRA	R	6/29/2022	10.23		046904		
	I-009961 Deadbolt - LCRA	R	6/29/2022	47.93		046904		
	I-010006 Bolts & Screws - UT	R	6/29/2022	90.47		046904		
	I-010052 Lock - UT	R	6/29/2022	16.08		046904		
	I-010055 Disc Flap - LCRA	R	6/29/2022	19.50		046904		
	I-010289 Cord - EM	R	6/29/2022	21.46		046904		288.23
03444	Mission Linen Supply							
	I-517255638 Uniform Pants - PL	R	6/29/2022	38.18		046905		
	I-517255639 Uniform Pants - MAINT	R	6/29/2022	28.27		046905		
	I-517255642 Uniform Pants - TP	R	6/29/2022	52.09		046905		118.54
00165	OJAI LUMBER CO, INC							
	I-2206-692914 Lumber - EM	R	6/29/2022	10.16		046906		
	I-2206-692933 Paint - UT	R	6/29/2022	20.55		046906		30.71
00383	ON DUTY UNIFORMS & EQUIPMENT							
	I-5816 Jacket - LCRA	R	6/29/2022	177.79		046907		
	I-5817 T-Shirts - LCRA	R	6/29/2022	372.77		046907		550.56
00790	PROFORMA							
	I-BI85007383A Uniform T Shirts - FISH	R	6/29/2022	142.10		046908		142.10

VENDOR I.D.	NAME	STATUS	CHECK DATE	INVOICE AMOUNT	DISCOUNT	CHECK NO	CHECK STATUS	CHECK AMOUNT
03554	J. Harris Industrial Water Tre Water Softner Serivce - WP	R	6/29/2022	160.97		046909		160.97
05976	Gregory Rivera Lifegurd Training - WP	R	6/29/2022	60.00		046910		60.00
02900	Greg Romey Reimburse Expenses 06/22	R	6/29/2022	111.76		046911		111.76
01109	SALVADOR LOERA TRANSPORTATION							
I-13096	Fill Sand - PL	R	6/29/2022	448.17		046912		
I-13097	Fill Sand - PL	R	6/29/2022	503.47		046912		
I-13098	Fill Sand - PL	R	6/29/2022	505.21		046912		
I-13099	Fill Sand - PL	R	6/29/2022	447.47		046912		
I-173395	DG - LCRA	R	6/29/2022	1,162.40		046912		3,066.72
00725	SMART & FINAL Coffee Cups - TP	R	6/29/2022	56.34		046913		56.34
00215	SOUTHERN CALIFORNIA EDISON							
I-062222a	Acct#700625798978	R	6/29/2022	206.64		046914		
I-062222b	Acct#700533992421	R	6/29/2022	28,332.69		046914		
I-062422	Acct#700237081885	R	6/29/2022	10,013.87		046914		38,553.20
00216	Southern California Gas Co.							
I-062822a	Acct#18231433006	R	6/29/2022	55.74		046915		
I-062822b	Acct#00801443003	R	6/29/2022	326.55		046915		382.29
02707	State Ready Mix Inc.							
I-628321	Slurry for Del Norte - PL	R	6/29/2022	935.86		046916		
I-628679	Slurry Mix - PL	R	6/29/2022	594.80		046916		1,530.66
02703	Sunbelt Rentals							
I-127380195-0001	Excavator Rental - PL	R	6/29/2022	1,155.16		046917		1,155.16
00498	BRIAN TAYLOR							
I-021522	Safety Boot Stipend	R	6/29/2022	205.00		046918		205.00
01396	VULCAN CONSTRUCTION MATERIALS							
I-73312879	Recycle Mixed Concrete - PL	R	6/29/2022	250.00		046919		250.00
03940	Wai & Connor LLP							
I-107874	Claim#1102WC180000002	R	6/29/2022	154.70		046920		
I-107875	Claim#1102WC030500101	R	6/29/2022	1,090.50		046920		
I-111223	Claim#1102WC030500101	R	6/29/2022	785.60		046920		
I-111450	Claim#1102WC030500101	R	6/29/2022	17.00		046920		
I-114811	Claim#1102WC170500002	R	6/29/2022	137.10		046920		
I-114812	Claim#1102WC180000002	R	6/29/2022	102.20		046920		

VENDOR I.D.	NAME	STATUS	CHECK DATE	INVOICE AMOUNT	DISCOUNT	CHECK NO	CHECK STATUS	CHECK AMOUNT
I-118192	Claim#1102WC180000002	R	6/29/2022	143.10		046920		
I-121741	Claim#1102WC170500002	R	6/29/2022	799.90		046920		
I-124629	Claim#1102WC170500002	R	6/29/2022	285.00		046920		
I-124630	Claim#1102WC180000002	R	6/29/2022	340.30		046920		
I-127888	Claim#1102WC170500002	R	6/29/2022	307.60		046920		
I-127889	Claim#1102WC180000002	R	6/29/2022	386.70		046920		
I-130864	Claim#1102WC170500002	R	6/29/2022	1,279.20		046920		
I-130865	Claim#1102WC180000002	R	6/29/2022	306.50		046920		
I-133681	Claim#1102WC170500002	R	6/29/2022	1,329.50		046920		
I-137110	Claim#1102WC170500002	R	6/29/2022	51.00		046920		
I-137111	Claim#1102WC180000002	R	6/29/2022	409.80		046920		
I-141033	Claim#1102WC180000002	R	6/29/2022	1,149.70		046920		
I-143351	Claim#1102WC170500002	R	6/29/2022	1,513.80		046920		
I-143356	Claim#1102WC180000002	R	6/29/2022	153.30		046920		
I-146301	Claim#1102WC170500002	R	6/29/2022	136.30		046920		
I-149363	Claim#1102WC170500002	R	6/29/2022	1,586.90		046920		
I-149366	Claim#1102WC180000001	R	6/29/2022	1,930.90		046920		
I-163786	Claim#1102WC180000002	R	6/29/2022	594.55		046920		
I-163789	Claim#1102WC180000001	R	6/29/2022	413.20		046920		
I-167388	Claim#1102WC180000001	R	6/29/2022	665.50		046920		
I-170706	Claim#1102WC180000001	R	6/29/2022	1,190.00		046920		
I-173972	Claim#1102WC180000002	R	6/29/2022	281.90		046920		
I-173973	Claim#1102WC180000001	R	6/29/2022	1,431.00		046920		
I-177437	Claim#1102WC180000002	R	6/29/2022	170.00		046920		
I-177439	Claim#1102WC180000001	R	6/29/2022	1,715.60		046920		
I-180776	Claim#1102WC180000002	R	6/29/2022	255.00		046920		
I-180779	Claim#1102WC180000001	R	6/29/2022	1,077.30		046920		
I-184703	Claim#1102WC180000001	R	6/29/2022	150.40		046920		
I-190576	Claim#1102WC180000001	R	6/29/2022	901.40		046920		
I-195554	Claim#1102WC180000001	R	6/29/2022	580.00		046920		
I-203668	Claim#1102WC180000001	R	6/29/2022	544.00		046920		
I-206542	Claim#1102WC180000001	R	6/29/2022	412.30		046920		
I-231579	Claim#1102WC180000001	R	6/29/2022	1,684.20		046920		
I-236070	Claim#1102WC180000001	R	6/29/2022	875.30		046920		
I-308014	Claim#1102WC170500002	R	6/29/2022	210.99		046920		
I-312607	Claim#1102WC170500002	R	6/29/2022	307.40		046920		
I-313956	Claim#1102WC170500002	R	6/29/2022	239.20		046920		
I-362956	Claim#1102WC180000001	R	6/29/2022	323.00		046920		28,418.84
00270	Wells Fargo Bank							
I-061022d	Gas - MGMT	R	6/29/2022	40.30		046924		
I-061022g	Employee Appreciation Even	R	6/29/2022	2,562.30		046924		
I-061022h	TeamViewer - ADM	R	6/29/2022	1,917.00		046924		
I-061022i	Water Tracer Dye - WP	R	6/29/2022	177.23		046924		
I-061022j	Water Fountain - LCRA	R	6/29/2022	1,419.36		046924		6,116.19

VENDOR I.D.	NAME	STATUS	CHECK DATE	INVOICE AMOUNT	DISCOUNT	CHECK NO	CHECK STATUS	CHECK AMOUNT
04010	CALIFORNIA STATE DISBURSEMENT							
I-CS5202206271993	200000001181291	R	6/29/2022	386.30		046925		386.30
00102	FRANCHISE TAX BOARD							
I-G03202206271993	Payroll Deduction	R	6/29/2022	778.37		046926		778.37
00124	ICMA RETIREMENT TRUST - 457							
I-DCI202206271993	DEFERRED COMP FLAT	R	6/29/2022	1,954.17		046927		
I-DI%202206271993	DEFERRED COMP PERCENT	R	6/29/2022	107.47		046927		2,061.64
00985	NATIONWIDE RETIREMENT SOLUTION							
I-CUN202206271993	457 CATCH UP	R	6/29/2022	480.77		046928		
I-DCN202206271993	DEFERRED COMP FLAT	R	6/29/2022	7,563.11		046928		
I-DN%202206271993	DEFERRED COMP PERCENT	R	6/29/2022	410.77		046928		8,454.65
03044	Amazon Capital Services							
I-13VF-Q7HL-4RCK	Office Supplies - DO	R	7/06/2022	93.70		046929		
I-194Q-GDVF-CMCC	Light Buld - LCRA	R	7/06/2022	82.94		046929		
I-1DT9-RT9P-WK9R	Vinyl Numbers Stickers - SAFE	R	7/06/2022	53.55		046929		
I-1KPF-Q4NV-4Q37	Thermostatic Mixing Valve-LCRA	R	7/06/2022	1,117.36		046929		
I-1M3L-YF7V-LV3D	Toner - DO	R	7/06/2022	929.38		046929		
I-1N4W-9YCK-P7XL	Mouse & Envelopes - ADM	R	7/06/2022	74.58		046929		
I-1NWX-136Q-QVX3	Phone Case - EM	R	7/06/2022	61.13		046929		
I-1R77-X7CG-KCR1	Mouse - PR	R	7/06/2022	150.12		046929		
I-1W6Y-9XYJ-KM4G	Arm Ext For Chanin Link - MAIN	R	7/06/2022	106.18		046929		
I-1WXQ-VP49-GYY6	Storage Organizer - PR	R	7/06/2022	276.88		046929		2,945.82
00014	AQUA-FLO SUPPLY							
I-SI1942866	Fittings - WP	R	7/06/2022	41.16		046930		
I-SI1947097	Fittings - WP	R	7/06/2022	31.35		046930		
I-SI1948253	Valve - LCRA	R	7/06/2022	34.63		046930		
I-SI1949128	FITTINGS - LCRA	R	7/06/2022	26.41		046930		133.55
02179	Art Street Interactive							
I-2440	Reservation Sys. Hosting/Maint	R	7/06/2022	549.70		046931		549.70
04421	Ben Arellanes Cultural Resourc							
I-6322	Fairview Pl Construction - ENG	R	7/06/2022	2,915.00		046932		
I-6622	Fairview PL Construction - ENG	R	7/06/2022	3,657.50		046932		6,572.50
03059	Brenntag Pacific Inc.							
I-BPI252289	Sodium Bisulfite - TP	R	7/06/2022	800.83		046933		800.83

VENDOR I.D.	NAME	STATUS	CHECK DATE	INVOICE AMOUNT	DISCOUNT	CHECK NO	CHECK STATUS	CHECK AMOUNT
00065	CALIFORNIA PARK & REC SOCIETY CPRS Membership	R	7/06/2022	555.00		046934		555.00
05756	Cel Analytical Inc Cryptosporidium Raw Sample	R	7/06/2022	405.00		046935		405.00
05964	Charter Communications Holding Acct#8448200220232531	R	7/06/2022	685.00		046936		685.00
02339	Clark Engineering Construction SA Vessel Walkway - ENG	R	7/06/2022	47,992.64		046937		60,614.59
	I-56075 Pipe Rack - MAINT	R	7/06/2022	12,621.95		046937		
01843	COASTAL COPY Copier Usage - WH	R	7/06/2022	156.85		046938		683.23
	I-1017519 Copier Usage - DO	R	7/06/2022	526.38		046938		
00752	COLE-FARMER INSTRUMENT CO. Micropopettor & Innocal Nist	R	7/06/2022	291.16		046939		291.16
01764	DataProse, LLC UB Mailing 05/22 Correction	R	7/06/2022	4,154.35CR		046940		4,126.30
	I-DP2202089b UB Mailing 05/22 Correction	R	7/06/2022	4,068.01		046940		
	I-DP2202524 UB Mailing 06/22	R	7/06/2022	4,212.64		046940		
00086	E.J. Harrison & Sons Inc Acct#500766090	R	7/06/2022	556.17		046941		556.17
00095	FAMCON PIPE & SUPPLY Weld Flange - PL	R	7/06/2022	139.43		046942		139.43
00099	FGL ENVIRONMENTAL Plant Effluent DBP 05/03/22	R	7/06/2022	245.00		046943		480.00
	I-208324A Nitrate Monitoring 05/17/22	R	7/06/2022	54.00		046943		
	I-209134A Nitrate Monitoring 05/31/22	R	7/06/2022	54.00		046943		
	I-209610A Nitrate Monitoring 06/07/22	R	7/06/2022	73.00		046943		
	I-210002A Nitrate Monitoring 06/14/22	R	7/06/2022	54.00		046943		
00713	FLUID MANUFACTURING Tokens - LCRA	R	7/06/2022	1,974.63		046944		1,974.63
01614	FORBESS CONSULTING GROUP, INC Lead Paint Testing - ENG	R	7/06/2022	1,040.00		046945		1,040.00

VENDOR I.D.	NAME	STATUS	CHECK DATE	INVOICE AMOUNT	DISCOUNT	CHECK NO	CHECK STATUS	CHECK AMOUNT
00104	FRED'S TIRE MAN							
I-140764	Oil Change Service - Unit 44	R	7/06/2022	273.21		046946		
I-140780a	Tires - Unit 47	R	7/06/2022	1,001.14		046946		1,274.35
02720	Garda CL West, Inc.							
I-10699004	Armored Truck Service	R	7/06/2022	522.05		046947		522.05
04467	General Pump Company, Inc.							
I-29478	Mutual Well 6 Rehab - ENG	R	7/06/2022	47,303.82		046948		47,303.82
05932	Ghitterman Ghitterman & Feld F							
I-070622	1102WC180000001 06/25-07/08/22	R	7/06/2022	580.00		046949		580.00
00491	GIBBS INTERNATIONAL TRUCK CTR							
I-458713	Repair - Unit 69	R	7/06/2022	1,344.30		046950		1,344.30
04022	Hammer, Jewell & Associates							
I-201680	Ventura-SB Row Srvs - ENG	R	7/06/2022	4,856.25		046951		4,856.25
00127	INDUSTRIAL BOLT & SUPPLY							
I-231968-1	Fittings - WP	R	7/06/2022	14.42		046952		14.42
05811	Instrument & Valve Services Co							
I-3790247	Mutual Well & Equip. - ENG	R	7/06/2022	10,704.60		046953		10,704.60
00667	Kennedy/Jenks Consultants, Inc							
I-156024	Heidelberger Boost Wall Design	R	7/06/2022	40,333.80		046954		
I-156025	Wellfield Support - ENG	R	7/06/2022	2,010.00		046954		
I-156028	On-Call Wellfield Tech - ENG	R	7/06/2022	2,332.50		046954		
I-156029R	Grant Support - ENG	R	7/06/2022	878.75		046954		45,555.05
05979	Sal Magallon							
I-1108871	Day Use Refund - LCRA	R	7/06/2022	20.00		046955		20.00
00329	MCMMASTER-CARR SUPPLY CO.							
I-80379946	Pulley for Wire Rope - ENG	R	7/06/2022	62.94		046956		62.94
00151	MEINERS OAKS ACE HARDWARE							
I-006271	Padlock - WP	R	7/06/2022	89.25		046957		
I-006772	Padlock & Broom - WP	R	7/06/2022	77.83		046957		
I-009781	Rincon Tank Roof Repair - EM	R	7/06/2022	224.61		046957		
I-009914	Painting Supplies - MAINT	R	7/06/2022	24.35		046957		
I-010227	Painting Supplies - MAINT	R	7/06/2022	45.98		046957		
I-010239	Sanddisck - WP	R	7/06/2022	4.48		046957		
I-010345	Insect Killer - MAINT	R	7/06/2022	5.83		046957		
I-010383	Toiler Flapper - LCRA	R	7/06/2022	38.04		046957		
I-010384	Mini Mats - LCRA	R	7/06/2022	12.86		046957		
I-010435	Fittings - TP	R	7/06/2022	70.07		046957		

VENDOR I.D.	NAME	STATUS	CHECK DATE	INVOICE AMOUNT	DISCOUNT	CHECK NO	CHECK STATUS	CHECK AMOUNT
I-010449	Primer & Sealer - LCRA	R	7/06/2022	15.95		046957		
I-010493	Flapper - LCRA	R	7/06/2022	11.70		046957		
I-010494	Cord Extn & Power Strips -MAIN	R	7/06/2022	124.00		046957		
I-010526	Runner CNCRD Char - EM	R	7/06/2022	119.91		046957		
I-010530	Padlock & Disc - WP	R	7/06/2022	68.47		046957		
I-010566	Viper ADA - LCRA	R	7/06/2022	283.02		046957		
I-010616	Rope, Tape & Paint - UT	R	7/06/2022	107.52		046957		
I-010712	Masking Tape - LCRA	R	7/06/2022	25.24		046957		
I-010741	Fittings - PL	R	7/06/2022	11.47		046957		
I-010747	Bolts & Screws - LCRA	R	7/06/2022	39.63		046957		
I-010990	Acetone & Shoptowel - UT	R	7/06/2022	26.33		046957		1,426.54
00143	METTLER TOLEDO, INC.							
I-634821355	ASTM Class 1 - LAB	R	7/06/2022	205.45		046959		205.45
03444	Mission Linen Supply							
I-517299854	Uniform Pants - PL	R	7/06/2022	32.36		046960		
I-517299855	Uniform Pants - MAINT	R	7/06/2022	28.27		046960		
I-517299859	Uniform Pants - TP	R	7/06/2022	52.09		046960		112.72
05977	ODP Business Solutions, LLC							
I-247176597001	Office Supplies - PR	R	7/06/2022	71.07		046961		
I-251173951001	Office Supplies - DO	R	7/06/2022	409.82		046961		
I-251179458001	Office Supplies - DO	R	7/06/2022	28.94		046961		509.83
01570	Ojai Auto Supply							
I-547249	Lamp - LCRA	R	7/06/2022	6.89		046962		
I-547304	Battery - Unit 57	R	7/06/2022	139.40		046962		
I-547350	Right Angle - LCRA	R	7/06/2022	2.31		046962		
I-547423	Lamp & Round Vheicle -Unit 234	R	7/06/2022	41.12		046962		
I-547580	WD 40 & Engine Oil - GARAGE	R	7/06/2022	141.97		046962		331.69
00165	OJAI LUMBER CO, INC							
I-2207-694201	Peeler Rope - WP	R	7/06/2022	77.29		046963		77.29
00168	OJAI VALLEY NEWS							
I-061322	1 Year Subscription	R	7/06/2022	540.80		046964		540.80
00947	CITY OF OJAI							
I-PW070522	Encroachment Permits	R	7/06/2022	1,464.00		046965		1,464.00
00734	OneSource Distributors, LLC							
I-S6942857.001	60 HP Motor VFD Filter - ENG	R	7/06/2022	3,080.52		046966		3,080.52

VENDOR I.D.	NAME	STATUS	CHECK DATE	INVOICE AMOUNT	DISCOUNT	CHECK NO	CHECK STATUS	CHECK AMOUNT
00188	PETTY CASH							
I-062922	Replenish Petty Cash - DO	R	7/06/2022	425.91		046967		425.91
05848	Public Risk, Innovation, Solut							
I-23100111	Excess Workers Comp Insurance	R	7/06/2022	176,294.00		046968		176,294.00
00790	PROFORMA							
I-BI85006869A	Two Tone Vest - LCRA	R	7/06/2022	960.05		046969		960.05
10042	PSR ENVIRONMENTAL SERVICE, INC							
I-10904	Gas Tank Inspection - DO	R	7/06/2022	265.00		046970		
I-10905	Gas Tank Inspection - LCRA	R	7/06/2022	265.00		046970		530.00
02767	Pueblo Water Resources, Inc.							
I-2022-68	Wellfield Support - ENG	R	7/06/2022	5,280.00		046971		5,280.00
04304	Signa Mechanical							
I-220519	Annual Sentry Advisor - LCRA	R	7/06/2022	125.00		046972		125.00
00204	SOAP MAN DISTRIBUTING OF							
I-55590	Garage Supplies - PL	R	7/06/2022	973.47		046973		973.47
00215	SOUTHERN CALIFORNIA EDISON							
I-062822	Acct#700387230310	R	7/06/2022	23.40		046974		
I-070122	Acct#700028735181	R	7/06/2022	19,032.18		046974		19,055.58
01147	SUPERIOR GATE SYSTEMS							
I-4719	Gate Reair - MAINT	R	7/06/2022	350.00		046975		350.00
09465	TRAVIS AGRICULTURAL CONSTRUCTI							
I-2196413	Mutual Well 7 Equip Contract	R	7/06/2022	27,183.94		046976		27,183.94
00225	UNDERGROUND SERVICE ALERT							
I-620220097	CAS01 New Ticket - ENG	R	7/06/2022	280.60		046977		
I-dsb20211552	Regulatory Costs - ENG	R	7/06/2022	78.70		046977		359.30
00257	VENTURA RIVER WATER DISTRICT							
I-063022	Acct#5-37500A	R	7/06/2022	188.11		046978		188.11
00247	County of Ventura							
I-336628	Encroachment Permit PE21-1059-	R	7/06/2022	170.00		046979		
I-337100	Encroachment Permit PE22-0187-	R	7/06/2022	170.00		046979		
I-337102	Encroachment Permit PE22-0212-	R	7/06/2022	170.00		046979		
I-338212	Encroachment Permit PE21-0832-	R	7/06/2022	170.00		046979		680.00

VENDOR I.D.	NAME	STATUS	CHECK DATE	INVOICE AMOUNT	DISCOUNT	CHECK NO	CHECK STATUS	CHECK AMOUNT
00250	COUNTY OF VENTURA							
I-IN0228403	CUPA Fees - Signal	R	7/06/2022	624.28		046980		
I-IN0228404	CUPA Fees - Heidelberg	R	7/06/2022	624.28		046980		
I-IN0228405	CUPA Fees - Montana/Cuyama	R	7/06/2022	707.40		046980		
I-IN0228406	CUPA Fees - San Antonio - TP	R	7/06/2022	1,123.00		046980		
I-IN0228407	CUPA Fees - Mutual Plant - TP	R	7/06/2022	873.64		046980		3,952.60
02515	Water Quality Solutions, Inc.							
I-346	Limnological WQ Analysis - LAB	R	7/06/2022	25,900.00		046981		25,900.00
00663	WAXIE SANITARY SUPPLY							
I-80992188	Janitorial Supplies - LCRA	R	7/06/2022	1,251.88		046982		1,251.88
00826	STAN WHISENHUNT DBA							
I-6502	Water Quality Report - PR	R	7/06/2022	850.00		046983		850.00
00330	WHITE CAP CONSTRUCTION SUPPLY							
I-10016107567	Mesh Silver Sand - WP	R	7/06/2022	13.67		046984		
I-50019024423	Dewatering/Trash Pump - PL	R	7/06/2022	608.32		046984		621.99
10048	WORLD WATERPARK ASSOCIATION							
I-053122	Membership Dues - WP	R	7/06/2022	459.00		046985		459.00
04582	Yeh and Associates, Inc							
I-222-227-1	Material Testing Ojai Ave Pipe	R	7/06/2022	611.00		046986		611.00
1	S&B BROOKS FAMILY							
I-000202206301996	US REFUND	R	7/06/2022	7.17		046987		7.17
1	JOBES, JACK							
I-000202206301997	US REFUND	R	7/06/2022	16.11		046988		16.11
1	GENERAL PAVEMENT MAN							
I-000202206301998	US REFUND	R	7/06/2022	234.99		046989		234.99
1	FISHMAN, DAVID							
I-000202206302000	US REFUND	R	7/06/2022	51.32		046990		51.32
1	MULLER, JENNIFER							
I-000202206301999	US REFUND	R	7/06/2022	126.75		046991		126.75
1	OJAI VALLEY BUSINESS							
I-000202207062001	US REFUND	R	7/06/2022	3,064.46		046992		3,064.46

VENDOR I.D.	NAME	STATUS	CHECK DATE	INVOICE AMOUNT	DISCOUNT	CHECK NO	CHECK STATUS	CHECK AMOUNT
-------------	------	--------	------------	----------------	----------	----------	--------------	--------------

* * T O T A L S * *		NO	INVOICE AMOUNT	DISCOUNTS	CHECK AMOUNT
REGULAR CHECKS:	161	2,042,310.29	0.00	2,042,310.29	
HAND CHECKS:	0	0.00	0.00	0.00	
DRAFTS:	11	173,838.08	0.00	173,838.08	
EFT:	0	0.00	0.00	0.00	
NON CHECKS:	0	0.00	0.00	0.00	
VOID CHECKS:	0	VOID DEBITS 0.00			
		VOID CREDITS 0.00	0.00	0.00	

TOTAL ERRORS: 0

VENDOR SET: 01	BANK: AP	TOTALS:	NO	INVOICE AMOUNT	DISCOUNTS	CHECK AMOUNT
			172	2,216,148.37	0.00	2,216,148.37
BANK: AP	TOTALS:		172	2,216,148.37	0.00	2,216,148.37
REPORT TOTALS:			172	2,216,148.37	0.00	2,216,148.37

Void Check #45392	(344.19)
Void Check #45759	(205.00)
Void Check #46674	(960.05)
	<u>\$2,214,639.13</u>

Adjudication Charge Fund Account

Publication of check register is in compliance with Section 53065.6 of the Government Code which requires the District to disclose reimbursements to employees and/or directors.

Adj. Checks: 000070-000074

Voids:



Janyne Brown , Chief Financial Officer

VENDOR I.D.	NAME	STATUS	CHECK DATE	INVOICE AMOUNT	DISCOUNT	CHECK NO	CHECK STATUS	CHECK AMOUNT
00306	Rincon Consultants, Inc.							
I-40182	Ventura River CDFW Flow Study	R	6/22/2022	5,693.15		000070		5,693.15
00270	Wells Fargo Bank							
I-061022b	Lunch - ADJ	R	6/22/2022	191.84		000071		
I-061022c	Lunch - ADJ	R	6/22/2022	156.93		000071		348.77
01703	ARNOLD LAROCHELLE MATTHEWS							
I-5811b	Adjudication Litigation 05/22	R	6/29/2022	736.00		000072		736.00
02475	Rutan & Tucker, LLP							
I-931029	Adjudication Litigation 05/22	R	6/29/2022	13,905.27		000073		13,905.27
00270	Wells Fargo Bank							
I-06/10221	Food Adjudication Mediation	R	6/29/2022	45.34		000074		
I-061022e	Lunch for City of Ojai Meeting	R	6/29/2022	105.20		000074		
I-061022f	Food Adjudication Mediation	R	6/29/2022	237.79		000074		
I-061022k	Food & Bev Adjudication Mediat	R	6/29/2022	34.58		000074		422.91

* * T O T A L S * *

	NO	INVOICE AMOUNT	DISCOUNTS	CHECK AMOUNT
REGULAR CHECKS:	5	21,106.10	0.00	21,106.10
HAND CHECKS:	0	0.00	0.00	0.00
DRAFTS:	0	0.00	0.00	0.00
EFT:	0	0.00	0.00	0.00
NON CHECKS:	0	0.00	0.00	0.00
VOID CHECKS:	0	VOID DEBITS 0.00		
		VOID CREDITS 0.00	0.00	0.00

TOTAL ERRORS: 0

	NO	INVOICE AMOUNT	DISCOUNTS	CHECK AMOUNT
VENDOR SET: 01 BANK: ADJ TOTALS:	5	21,106.10	0.00	21,106.10
BANK: ADJ TOTALS:	5	21,106.10	0.00	21,106.10
REPORT TOTALS:	5	21,106.10	0.00	21,106.10

Casitas Municipal Water District
Reimbursement Disclosure Report (1)
Fiscal Year 2021/22
July 1, 2021-June 30, 2022

<u>Date paid</u>	<u>Board of Director/Employee</u>	<u>Description</u>	<u>Amount Paid</u>
7/14/2021	Scott Lewis	Fisheries Supplies	\$ 222.44
7/14/2021	Scott Lewis	Car Rental 06/04-06/17	\$ 1,217.44
7/14/2021	Scott Lewis	Hotel 06/06-06/16	\$ 957.00
7/14/2021	Brian Taylor	Hotel 06/20-06/24	\$ 858.94
7/14/2021	Aaron Wall	ARC Lifeguard Instructor Review	\$ 120.00
7/21/2021	Jesus Garcia	Safety Boot Stipend	\$ 170.00
7/21/2021	David Pope	Work T-Shirts	\$ 204.85
7/28/2021	Corban Suggs	Tuition Reimbursement	\$ 319.00
8/11/2021	Gonzalo Carbajal-Ramirez	Safety Boot Stipend	\$ 170.00
8/11/2021	Ramiro Garcia	Safety Boot Stipend	\$ 170.00
8/11/2021	Vincent Godinez	Safety Boot Stipend	\$ 170.00
8/11/2021	Spencer Hair	Safety Boot Stipend	\$ 170.00
8/11/2021	Gerardo M Herrera	Safety Boot Stipend	\$ 170.00
8/11/2021	Eric Lara	Safety Boot Stipend	\$ 170.00
8/11/2021	Mario Mariscal	Safety Boot Stipend	\$ 170.00
8/11/2021	Luis Mejia	Safety Boot Stipend	\$ 170.00
8/11/2021	David Pope	Safety Boot Stipend	\$ 170.00
8/11/2021	Edgar Ramos Jr.	Safety Boot Stipend	\$ 170.00
8/11/2021	Michael Robles	Safety Boot Stipend	\$ 170.00
8/11/2021	Jose Ruiz	Safety Boot Stipend	\$ 170.00
8/11/2021	Brian Taylor	Safety Boot Stipend	\$ 170.00
8/18/2021	Gerardo M Herrera	Class Expenses	\$ 168.00
8/25/2021	Luke Soholt	Property Taxes Damtender's Residence	\$ 386.26
9/22/2021	Michael Gibson	Private Vehicle Mileage	\$ 122.64
9/22/2021	Scott Lewis	Hotel 08/14/21-08/25/21	\$ 1,105.94
9/22/2021	Scott Lewis	Car Rental 08/13/21-08/26/21	\$ 1,533.05
10/6/2021	Lindsay Cao	CWEA Renewal	\$ 192.00
10/6/2021	Joel Cox	Distribution 4 Certification	\$ 235.00
10/6/2021	Joe Martinez III	WWA Symposium - Advance	\$ 1,240.00
10/13/2021	Willis Hand	T5 Renewal of Certification	\$ 105.00
10/13/2021	Ian McMahon	Pressure Hose - Unit 95	\$ 158.41
10/20/2021	Michael Shields	D5 Certification Renewal	\$ 105.00
10/27/2021	Scott Lewis	Hotel 09/25/21-10/02/21	\$ 658.42
11/3/2021	Gerardo M Herrera	Class Registration	\$ 151.00
11/3/2021	Joe Martinez III	WWA Trade Show	\$ 499.00
11/3/2021	Aaron Wall	Flight WWA Trade Show	\$ 217.92
11/3/2021	Aaron Wall	Hotel 10/17/21-10/21/21 WWA Trade Ahow	\$ 1,427.60
11/3/2021	Aaron Wall	Garage Door	\$ 462.25
11/10/2021	Alex Kelso	Water Treatment Plan Operation Class	\$ 166.53
11/17/2021	Greg Romey	Food & Drinks for Crew - Main Leak	\$ 171.62
11/17/2021	Greg Romey	ASSP Membership Renewal	\$ 230.00
12/1/2021	Scott Lewis	Hotel 11/14/21-11/21/21	\$ 626.22
12/8/2021	Alex Kelso	CL17 Analysis of Chlorine Class	\$ 160.00
12/8/2021	Keegan Shirck	Safety Boot Stipend	\$ 170.00
12/8/2021	John Simon	Safety Boot Stipend	\$ 170.00
12/15/2021	Jesus Garcia	Class A License	\$ 595.00
12/15/2021	Ramiro Garcia	Grade 3 Water Treatment Exam	\$ 100.00
12/15/2021	Aaron Wall	Safety Boot Stipend	\$ 170.00
12/29/2021	Evan Helm	Specialized Paint for robes Vaki	\$ 166.19
1/5/2022	Ramiro Garcia	Water & Wastewater Management Class	\$ 171.00
1/5/2022	Edgar Ramos Jr.	Water Treatment Class	\$ 171.00
1/12/2022	Scott Lewis	Hotel 12/11/21-12/20/21	\$ 1,091.12
1/12/2022	Scott Lewis	Fall Term Tuition	\$ 2,131.71
1/12/2022	William Reeder	Water Treatment Operator	\$ 105.00
1/12/2022	William Reeder	Water Treatment operation Volume 2	\$ 171.53

Casitas Municipal Water District
Reimbursement Disclosure Report (1)
Fiscal Year 2021/22
July 1, 2021-June 30, 2022

1/12/2022	Corban Suggs	College Class	\$	171.00
1/12/2022	Corban Suggs	Textbook	\$	173.19
1/19/2022	Luke Soholt	Lunch for Employees	\$	183.56
2/2/2022	Joe Evans	LDF Fee for Park Rangers	\$	315.00
2/9/2022	Julia Aranda	Office Supplies	\$	182.40
2/9/2022	Gonzalo Carbajal-Ramirez	Hotel - Cla-Val Class	\$	241.40
2/9/2022	Scott Lewis	Airfare	\$	514.20
2/9/2022	Scott Lewis	Hotel 01/05/22-01/09/22	\$	361.00
2/9/2022	Scott Lewis	Fisheries Supplies	\$	109.26
2/9/2022	Scott Lewis	Fisheries Supplies	\$	109.34
2/9/2022	Edgar Ramos Jr.	Hotel - Cla-Val Class	\$	242.40
2/9/2022	Edgar Ramos Jr.	Auto Miles	\$	139.23
2/9/2022	Steven Sharp	Drinking Water Operator Certification	\$	155.00
2/16/2022	Eric Behrendt	Safety Boot Stipend	\$	205.00
2/16/2022	Lindsay Cao	Safety Boot Stipend	\$	205.00
2/16/2022	Gonzalo Carbajal-Ramirez	Safety Boot Stipend	\$	205.00
2/16/2022	Virgil Clary	Safety Boot Stipend	\$	205.00
2/16/2022	Joel Cox	Safety Boot Stipend	\$	205.00
2/16/2022	Alvin Domingo	Safety Boot Stipend	\$	205.00
2/16/2022	Todd Evans	Safety Boot Stipend	\$	205.00
2/16/2022	Jesus Garcia	Safety Boot Stipend	\$	170.00
2/16/2022	Ramiro Garcia	Safety Boot Stipend	\$	205.00
2/16/2022	Vincent Godinez	Safety Boot Stipend	\$	205.00
2/16/2022	Ken Grinnell	Safety Boot Stipend	\$	205.00
2/16/2022	Willis Hand	Safety Boot Stipend	\$	205.00
2/16/2022	Gerardo M Herrera	Safety Boot Stipend	\$	205.00
2/16/2022	Eric Lane	Safety Boot Stipend	\$	205.00
2/16/2022	Eric Lara	Safety Boot Stipend	\$	205.00
2/16/2022	Tim Lawson	Safety Boot Stipend	\$	205.00
2/16/2022	Ivan Lopez	Safety Boot Stipend	\$	205.00
2/16/2022	Scott MacDonald	Safety Boot Stipend	\$	205.00
2/16/2022	Mario Mariscal	Safety Boot Stipend	\$	205.00
2/16/2022	Ian McMahon	Safety Boot Stipend	\$	205.00
2/16/2022	Luis Mejia	Safety Boot Stipend	\$	205.00
2/16/2022	Gustavo Muro	Safety Boot Stipend	\$	205.00
2/16/2022	Curtis Orozco	Safety Boot Stipend	\$	205.00
2/16/2022	David Pope	Safety Boot Stipend	\$	205.00
2/16/2022	Edgar Ramos Jr.	Safety Boot Stipend	\$	205.00
2/16/2022	William Reeder	Safety Boot Stipend	\$	205.00
2/16/2022	Michael Robles	Safety Boot Stipend	\$	205.00
2/16/2022	Jose Ruiz	Safety Boot Stipend	\$	205.00
2/16/2022	Steven Sharp	Safety Boot Stipend	\$	205.00
2/16/2022	Luke Soholt	Safety Boot Stipend	\$	205.00
2/16/2022	Jordan Switzer	Safety Boot Stipend	\$	205.00
2/16/2022	Brian Taylor	Safety Boot Stipend	\$	205.00
2/23/2022	Mitch Abel	Safety Boot Stipend	\$	205.00
2/23/2022	Curtis Bowles	Safety Boot Stipend	\$	170.00
2/23/2022	Scot Byron	Safety Boot Stipend	\$	205.00
2/23/2022	Kyler Heath	Safety Boot Stipend	\$	205.00
2/23/2022	Joshua Malagon	Safety Boot Stipend	\$	205.00
2/23/2022	Ron Quinine	Safety Boot Stipend	\$	205.00
2/23/2022	Stephen Sulkowski	Safety Boot Stipend	\$	205.00
3/2/2022	Michael Gibson	Waders & Wading Boots	\$	811.48
3/2/2022	Alex Kelso	Grade 4 Treatment Operator Certification	\$	130.00
3/2/2022	Ian McMahon	Hotel - Cla-Val Class	\$	242.40
3/9/2022	Stuart Birdsey	Safety Boot Stipend	\$	205.00

Casitas Municipal Water District
Reimbursement Disclosure Report (1)
Fiscal Year 2021/22
July 1, 2021-June 30, 2022

3/9/2022	Eric Lara	Course Registration	\$ 299.99
3/9/2022	Greg Romey	ASSP Training	\$ 1,350.00
3/9/2022	Greg Romey	Food & Drinks for Crew - Assisting with Ammonia Tanks	\$ 120.49
3/9/2022	Keegan Shirck	Hotel - Cla-Val Class	\$ 242.40
3/9/2022	John Simon	Distribution 4 Certification	\$ 299.99
3/9/2022	Vincent Godinez	Hotel - Cla-Val Class	\$ 132.32
3/30/2022	Vincent Godinez	Auto Miles	\$ 139.23
3/30/2022	Scott MacDonald	Auto Miles	\$ 140.40
3/30/2022	Patrick McCue	Safety Boot Stipend	\$ 205.00
4/6/2022	Michael Shields	Operator Certification Renewing	\$ 105.00
4/20/2022	Scot Byron	Hotel - AWWA Conference	\$ 966.54
4/20/2022	Scot Byron	Auto Miles	\$ 121.68
4/20/2022	Ramiro Garcia	Hotel - AWWA Conference	\$ 861.03
4/20/2022	Ramiro Garcia	Auto Miles	\$ 134.55
4/20/2022	Corban Suggs	Hotel - AWWA Conference	\$ 966.54
4/27/2022	Michael Gibson	American Fisheries Society Membership	\$ 110.00
4/27/2022	Travis Larson	Safety Boot Stipend	\$ 205.00
4/27/2022	Corban Suggs	Grade T3 Exam	\$ 100.00
5/4/2022	Ramiro Garcia	Hotel - Cla-Val Class	\$ 255.74
5/4/2022	Luis Mejia	Hotel - Cla-Val Class	\$ 270.22
5/4/2022	Luis Mejia	Auto Miles	\$ 129.87
5/4/2022	John Simon	Auto Miles	\$ 127.53
5/18/2022	Jesus Garcia	Class A License Training	\$ 795.00
5/18/2022	Eric Lara	Distribution 2 Certification	\$ 125.00
5/19/2022	Corban Suggs	Office Supplies	\$ 193.76
5/25/2022	Vincent Godinez	Distribution 4 Certification	\$ 105.00
5/25/2022	Alex Kelso	Safety Boot Stipend	\$ 205.00
6/1/2022	Edgar Ramos Jr.	Water & Wastewater Hydraulics Class	\$ 312.00
6/8/2022	Keegan Shirck	Safety Boot Stipend	\$ 205.00
6/8/2022	John Simon	Safety Boot Stipend	\$ 205.00
6/8/2022	Corban Suggs	Safety Boot Stipend	\$ 205.00
6/8/2022	Corban Suggs	Water Chem. Class	\$ 353.00
6/8/2022	Corban Suggs	Textbook	\$ 185.10
6/8/2022	Brian Taylor	Foldable Shop Crane	\$ 235.94
6/8/2022	Brian Taylor	AWWA Spring Conference Lodging	\$ 2,010.57
6/15/2022	Scot Byron	Water Treatment and Distribution Certificate	\$ 499.98
6/15/2022	Ramiro Garcia	Water & Wastewater Hydraulics Class	\$ 312.00
6/15/2022	Scott Lewis	Hotel - Workshop	\$ 248.97
6/15/2022	Scott Lewis	Airfare	\$ 592.20
6/15/2022	Scott Lewis	Hotel	\$ 518.00
6/15/2022	Scott Lewis	Toner	\$ 289.97
6/2/2022	Efren Alvarez	Accounting Class	\$ 275.00
6/30/2022	Brian Taylor	Coolers & Water for PL Crew	\$ 141.45

1) Reimbursement Disclosure Report prepared pursuant to California Government Code 53065.5

Minutes of the Casitas Municipal Water District
Board Meeting Held
June 22, 2022

1. CALL TO ORDER

President Brennan called the meeting to order at 5:00 p.m.

2. ROLL CALL

Directors Bergen, Kaiser, Cole, Hajas and Brennan are present. Also present are GM Flood, AGM Dyer, and EA Vieira. Counsel Mathews attends the meeting via Zoom.

3. PLEDGE OF ALLEGIANCE

President Brennan led the Pledge of Allegiance

4. AGENDA CONFIRMATION

GM Flood apprised the board that the title in item 7f should not have included the Mira Monte Fund as it has already been paid off. The resolution in the agenda packet is correct. On item 8e there is an extra zero. The amount should read \$2.7 Million.

5. PUBLIC COMMENTS - Presentation on District related items that are not on the agenda - three minute limit.

Burt Handy questioned the video feed and also not seeing consumption reports to compare to the Ventura reporting. President Brennan informed him that we are working to resolve some of the issues with the hybrid meeting. GM Flood added that the zoom is audio only at this time.

6. CONSENT AGENDA

6.a. Accounts Payable Report.
[Accounts Payable Report.pdf](#)

6.b. Minutes of the June 8, 2022 Board Meeting.
[6 08 2022 Min.pdf](#)

6.c. Resolution proclaiming a local emergency persists, re-ratifying the proclamation of a state of emergency by Executive Order and re-authorizing remote teleconference meetings of the legislative bodies of Casitas Municipal Water District for the period of June 23, 2022 to July 22, 2022 pursuant to Brown Act provisions.
[Resolution Subsequent AB 361.pdf](#)

The Consent Agenda was offered by Director Hajas, seconded by Director Kaiser and adopted by the following roll call vote:

AYES: Directors: Bergen, Kaiser, Cole, Hajas, Brennan
NOES: Directors: None
ABSENT: Directors: None

Resolution is numbered 2022-18

7. PUBLIC HEARING ON THE ADOPTION OF THE FISCAL YEAR 2022-2023 BUDGET.

7.a. Open Public Hearing.

[Board Memo for the Draft FY 2023 Budget Hearing 062222.pdf](#)
[Budget Document 6.2.22.pdf](#)

President Brennan opened the Public Hearing at 5:05 p.m.

7.b. Receive General Manager's Report and Recommendations.

GM Flood provided a presentation on the recommended Fiscal Year 2022-2023 Budget which assumes 12,500 AF in volume sales and a projected increase in rates of 3% in 2023. It is a balanced budget and we will pull \$2.4 million from cash reserves and will expend \$6.4 million of the remaining CFD funds. Mr. Flood explored districts investments and also provided answers for questions that were asked during the budget presentation the previous meeting. The increases to management service and supplies included additional money for legal counsel where we saw our first increase in rates in 14 years and also includes funding for additional experts working on the stream flow study. There is also an increase for travel and training related expenses for in person conferences.

7.c. Receive Report of Written Communications by the Clerk of the Board.

Clerk of the Board Vieira reported there were none.

7.d. Public Comments.

None

7.e. Close Public Hearing.

President Brennan closed the public hearing at 5:13 p.m.

7.f. Discussion by Board of Directors and Possible Adoption of the Resolution Approving the General Fund Budget, Debt Service Fund Budgets for the Fiscal Year Ending June 30, 2023. [Resolution Adopting General Fund Budget 2022-2023.pdf](#)

The resolution was offered by Director Bergen, seconded by Director Kaiser and adopted by the following roll call vote:

AYES: Directors: Bergen, Kaiser, Cole, Hajas, Brennan

NOES: Directors: None
ABSENT: Directors: None

Resolution is numbered 2022-19

8. ACTION ITEMS

- 8.a. Adopt Resolution fixing a tax rate for Fiscal Year 2022-2023 and authorizing the President of the Board to execute a certificate requesting the Ventura County Board of Supervisors to levy such a tax.
[Resolution for Tax Rate State Water 2022-2023.pdf](#)

The resolution was offered by Director Hajas, seconded by Director Kaiser and adopted on the following roll call vote:

AYES: Directors: Bergen, Kaiser, Cole, Hajas, Brennan
NOES: Directors: None
ABSENT: Directors: None

Resolution is numbered 2022-20

- 8.b. Adopt Resolution to authorize, under Proposition 4, the 2022-2023 Establishment of Appropriations Limit of \$16,867,937.
[Memo- Proposition 4 2022-2023.pdf](#)
[Resolution for Prop 4 - 2022-2023.pdf](#)

The resolution was offered by Director Cole, seconded by Director Bergen and adopted by the following roll call vote:

AYES: Directors: Bergen, Kaiser, Cole, Hajas, Brennan
NOES: Directors: None
ABSENT: Directors: None

Resolution is numbered 2022-21

- 8.c. Adopt Resolution authorizing the levy of a special tax for Fiscal Year 2022-2023 for Community Facilities District No. 2013-1 (Ojai).
[Casitas MWD CFD No. 2013-1 \(Ojai\) Reso Auth FY 2022-23 Levy.pdf](#)
[Exhibit 1 \(Special Tax Levy\) - Approval.pdf](#)

The resolution was offered by Director Hajas, seconded by Director Cole and adopted by the following roll call vote:

AYES: Directors: Bergen, Kaiser, Cole, Hajas, Brennan
NOES: Directors: None
ABSENT: Directors: None

Resolution is numbered 2022-22

- 8.d. Adopt a resolution approving the Casitas MWD Customer Bill Relief Program.
[Board Memo Regarding Proposed Bill Relief Program.pdf](#)
[ATT1_Proposed Bill Relief Program_Draft 061722.pdf](#)
[ATT2_Bill Relief Application \(3\).pdf](#)

The resolution was offered by Director Kaiser, seconded by Director Hajas and adopted by the following roll call vote:

AYES:	Directors:	Bergen, Kaiser, Cole, Hajas, Brennan
NOES:	Directors:	None
ABSENT:	Directors:	None

Resolution is numbered 2022-23

- 8.e. Adopt a Resolution regarding a \$2,700,000 loan to fund the replacement Aquatic Play Structure and Regenerative Filter System at the Casitas Water Adventure. [Board Memo CWA Improvement Loan 062222.pdf](#)
[CWA APS Reso Authorizing Installation Agreement 062222 ATT1.pdf](#) Draft
[CWA APS Installation Sale Agreement 062222 ATT2.pdf](#)

The board considered the financing options and with the understanding that the stated \$2.7 million for the project does not include costs, the board decided to amend the resolution to be \$2,765,000.00. The loan is secured by the district. The board discussed the looking into the possibility of a mid-week reduced rate for local customers.

On the motion of Director Cole, seconded by Director Bergen the resolution with the amended amount of \$2,765,000 was adopted by the following roll call vote:

AYES:	Directors:	Bergen, Kaiser, Cole, Hajas, Brennan
NOES:	Directors:	None
ABSENT:	Directors:	None

Resolution is numbered 2022-24

- 8.f. Approve and file the Notice of Exemption and Award contract for Emergency Generator at Rincon Pump Plant (Specification No. 21-447) to Taft Electric in the amount of \$1,551,500.
[Board Memo_Emergency Generators Award 06142022.pdf](#)
[Backup Diesel Generators-CE Environmental Impact Analysis with Attachment A_2022-0614.pdf](#)
[Backup Diesel Generators-CE Memo_2022-0614.pdf](#) Backup
[Diesel Generators-NOE Form_2021-0913.pdf](#)

Director Hajas questioned why the use of Diesel and Director Kaiser questioned if it can take on new bio fuels. GM Flood responded yes and it is compliant with the latest air quality requirements.

Burt Handy asked about use of a propane tank and Mr. Flood responded we have not looked at that.

On the motion of Director Kaiser, seconded by Director Cole, the above recommendation was approved by the following roll call vote:

AYES:	Directors:	Bergen, Kaiser, Cole, Hajas, Brennan
NOES:	Directors:	None
ABSENT:	Directors:	None

- 8.g. Approve, and Authorize Board President to sign, Agreements with: 1) Michael K. Nunley & Associates, Inc.; 2) Water Works Engineers, LLC; 3) MNS Engineers, Inc.; 4) Kennedy/Jenks Consultants, Inc. and 5) Cannon Corporation, for on-call engineering services for Fiscal Year 2022-23.
[Board Memo_On-CallEngineeringFY22-23.docx.pdf](#)

On the motion of Director Hajas, seconded by Director Kaiser the above recommendation was approved by the following roll call vote:

AYES:	Directors:	Bergen, Kaiser, Cole, Hajas, Brennan
NOES:	Directors:	None
ABSENT:	Directors:	None

- 8.h. Approve, and Authorize Board President to sign, Agreements for on-call environmental consulting services for Fiscal Year 2022-23 with: Provost & Pritchard Consulting Group; Rincon Consultants; Padre Associates, Inc.; and Catalyst Environmental Solutions.
[Board Memo_On-CallEnvironmental_FY22-23.pdf](#)

Director Cole requested removal of Rincon Consultants from the list as they have gone overboard on some of their reviews as far as I have seen and \$6,000 is excessive for an exemption. Engineering Manager Aranda explained that they are all qualified. We had seven firms submit and called references and narrowed our list to four. In practicality, if the project is small scale we call one on the list. If the project is larger in scope we will ask the four of them for a proposal and compare them.

Director Bergen added because we only had one before there was no competition. The situation is different now and they will be aware there are others out there.

On the motion of Director Kaiser, seconded by Director Bergen, the above recommendation was approved by the following roll call vote:

AYES:	Directors:	Bergen, Kaiser, Hajas, Brennan
NOES:	Directors:	Cole
ABSENT:	Directors:	None

- 8.i. Approve, and Authorize Board President to sign, Agreements for on-call geotechnical services for Fiscal Year 2022-23 with: NV5 West, Inc; Bajada Geosciences, Inc.; and Yeh and Associates, Inc.
[Board Memo_On-Call Geotechnical_FY22-23.pdf](#)

On the motion of Director Kaiser, seconded by Director Cole, the above recommendation was approved by the following roll call votes:

AYES:	Directors:	Bergen, Kaiser, Cole, Hajas, Brennan
NOES:	Directors:	None
ABSENT:	Directors:	None

- 8.j. Extend the contract for Asphalt Paving, Specification No. 21-439 for Fiscal Year (FY) 2022-2023 to BSN Construction Inc. and Wingate Earthworks; and the President of the Board execute the agreements for said work.
[Board Memo- FY 2022-23 Asphalt.pdf](#)

On the motion of Director Kaiser, seconded by Director Bergen the above recommendation was approved by the following roll call vote:

AYES:	Directors:	Bergen, Kaiser, Cole, Hajas, Brennan
NOES:	Directors:	None
ABSENT:	Directors:	None

9. INFORMATION ITEMS

- 9.a. Receive and file the Water Year 2021 Hydrology Report.
[220607 - Final Annual Report WY 2021.pdf](#)
- 9.b. Receive and file May 2022 Hydrology Report.
[2205 May 2022.pdf](#)

The items were received.

10. GENERAL MANAGER COMMENTS

GM Flood explained to the board that we have asked our media firm to look on the secondary market for the cards that are needed to enable people to see and hear us on Zoom. We hope they may get them in a month.

Staff are working on SIP exception policy to allow for treatment on the lake with copper at a higher rate in the event of a Quagga incident. The ISMND is being released tomorrow and will be brought back to the board in August.

11. BOARD OF DIRECTOR REPORTS ON MEETINGS ATTENDED

None

12. BOARD OF DIRECTOR COMMENTS PER GOVERNMENT CODE SECTION 54954.2(a).

None

President Brennan moved the meeting to closed session at 5:57 p.m.

13. CLOSED SESSION

13.a. CONFERENCE WITH LEGAL COUNSEL – EXISTING LITIGATION (Government Code Section 54956.9(a) Santa Barbara Channelkeeper v. State Water Resources Control Board, City of San Buenaventura, et al.; and City of San Buenaventura v Duncan Abbott, et al., Cross Complaint; Superior Court of the State of California, County of Los Angeles, Case No. 19STCP01176.

President Brennan moved the meeting back into open session at 6:35 p.m. with Mr. Mathews reporting that no action was taken in closed session.

14. ADJOURNMENT

President Brennan adjourned the meeting at 6:36p.m.

Neil Cole, Secretary

CASITAS MUNICIPAL WATER DISTRICT

RESOLUTION NO. 2022-25

A RESOLUTION OF THE BOARD OF DIRECTORS OF THE CASITAS MUNICIPAL WATER DISTRICT PROCLAIMING A LOCAL EMERGENCY PERSISTS, RE-RATIFYING THE PROCLAMATION OF A STATE OF EMERGENCY BY EXECUTIVE ORDER, AND RE-AUTHORIZING REMOTE TELECONFERENCE MEETINGS OF THE LEGISLATIVE BODIES OF CASITAS MUNICIPAL WATER DISTRICT FOR THE PERIOD JULY 13, 2022 to AUGUST 12, 2022 PURSUANT TO BROWN ACT PROVISIONS.

WHEREAS, the Casitas Municipal Water District is committed to preserving and nurturing public access and participation in meetings of the Board of Directors; and

WHEREAS, all meetings of Casitas Municipal Water District's legislative bodies are open and public, as required by the Ralph M. Brown Act (Cal. Gov. Code 54950 – 54963), so that any member of the public may attend, participate, and watch the District's legislative bodies conduct their business; and

WHEREAS, the Brown Act, Government Code section 54953(e), makes provision for remote teleconferencing participation in meetings by members of a legislative body, without compliance with the requirements of Government Code section 54953(b)(3), subject to the existence of certain conditions; and

WHEREAS, a required condition is that a state of emergency is declared by the Governor pursuant to Government Code section 8625, proclaiming the existence of conditions of disaster or of extreme peril to the safety of persons and property within the state caused by conditions as described in Government Code section 8558; and

WHEREAS, a proclamation is made when there is an actual incident, threat of disaster, or extreme peril to the safety of persons and property within the jurisdictions that are within the District's boundaries, caused by natural, technological or human-caused disasters; and

WHEREAS, it is further required that state or local officials have imposed or recommended measures to promote social distancing, or, the legislative body meeting in person would present imminent risks to the health and safety of attendees; and

WHEREAS, the Board of Directors previously adopted a Resolution, Number 2021-23 on October 13, 2021, Resolution Number 2021-24 on November 10, 2021, Resolution Number 2021-26 on December 8, 2021, Resolution Number 2021-29 ON December 15, 2021, Resolution 2022-01 on January 12, 2022, Resolution Number 2022-05 on February 9, 2022, Resolution Number 2022-07 on March 9, 2022 and Resolution 2022-09 on March 23, 2022, Resolution 2022-11 on April 13, 2022, Resolution 2022-13 on May 11, 2022, Resolution 2022-16 on June 8, 2022 and Resolution 2022-18 on June 22, 2022 finding that the requisite conditions exist for the legislative bodies of Casitas Municipal Water District to conduct remote teleconference meetings without compliance with paragraph (3) of subdivision (b) of section 54953; and

WHEREAS, as a condition of extending the use of the provisions found in section 54953(e), the Board of Directors must reconsider the circumstances of the state of emergency that exists in the District, and the Board of Directors has done so; and

WHEREAS, emergency conditions persist in the District, specifically, a state of emergency remains active; and

WHEREAS, the Board of Directors does hereby find that State of Emergency, and Social Distancing requirements and conditions causing imminent risk to attendees has caused, and will continue to cause, conditions of peril to the safety of persons within the District that are likely to be beyond the control of services, personnel, equipment, and facilities of the District, and desires to affirm a local emergency exists and re-ratify the proclamation of state of emergency by the Governor of the State of California and local orders for social distancing; and

WHEREAS, as a consequence of the local emergency persisting, the Board of Directors does hereby find that the legislative bodies of Casitas Municipal Water District shall continue to conduct their meetings without compliance with paragraph (3) of subdivision (b) of Government Code section 54953, as authorized by subdivision (e) of section 54953, and that such legislative bodies shall continue to comply with the requirements to provide the public with access to the meetings as prescribed in paragraph (2) of subdivision (e) of section 54953; and

WHEREAS, Casitas Municipal Water District has taken measures to ensure meeting access for the public via the Zoom platform including electronic video and telephone access.

NOW, THEREFORE, THE BOARD OF DIRECTORS OF CASITAS MUNICIPAL WATER DISTRICT DOES HEREBY RESOLVE AS FOLLOWS:

Section 1. Recitals. The Recitals set forth above are true and correct and are incorporated into this Resolution by this reference.

Section 2. Affirmation that Local Emergency Persists. The Board of Directors hereby considers the conditions of the state of emergency in the District and proclaims that a local emergency persists throughout the District, and meeting in person would present imminent risk.

Section 3. Re-ratification of Governor's Proclamation of a State of Emergency. The Board hereby ratifies the Governor of the State of California's Proclamation of State of Emergency, effective as of its issuance date of March 4, 2020.

Section 4. Remote Teleconference Meetings. The Staff, General Manager and legislative bodies of Casitas Municipal Water District are hereby authorized and directed to take all actions necessary to carry out the intent and purpose of this Resolution including, continuing to conduct open and public meetings in accordance with Government Code section 54953(e) and other applicable provisions of the Brown Act.

Section 5. Effective Date of Resolution. This Resolution shall take effect immediately upon its adoption and shall be effective until the earlier of (i) August 12, 2022, or such time the Board of Directors adopts a subsequent resolution in accordance with Government Code section 54953(e)(3) to extend the time during which the legislative bodies of Casitas Municipal Water District may continue to teleconference without compliance with paragraph (3) of subdivision (b) of section 54953.

PASSED AND ADOPTED by the Board of Directors of Casitas Municipal Water District, this 13th day of July, 2022.

Brian Brennan, President

Attest:

Neil Cole, Secretary

**CASITAS MUNICIPAL WATER DISTRICT
MEMORANDUM**

TO: BOARD OF DIRECTORS
FROM: MICHAEL FLOOD, GENERAL MANAGER
SUBJECT: MUTUAL WELL #7 WELL EQUIPMENT AND SITE WORK, SPECIFICATION NO. 20-438 CHANGE ORDER #4
DATE: 07/13/2022

RECOMMENDATION:

- Approve Change Order No. 4 to Travis Agricultural Construction, Inc. for the Mutual Well #7 Well Equipment and Site Work, Specification No. 20-438 in the amount of \$12,565.35.

BACKGROUND AND DISCUSSION:

The Mutual Well #7 well drilling contract was specified with a stainless steel casing and the well equipping contract was specified with a carbon steel casing. The well casing extension is required to be stainless steel to eliminate potential corrosion issues from dissimilar metals.

The attached Change Order No. 4 describes the additional cost for the modifications required to convert to a stainless steel casing extension with appurtenances. Since the cumulative change order amount exceeds 5 percent of the original contract, Board approval is required. The table below summarizes the contract change orders to date.

Original Contract Amount	\$1,232,667.00
Change Order No. 1	\$ 33,646.73
Change Order No. 2	\$ 20,312.30
Change Order No. 3	\$ 18,231.15
Change Order No. 4	\$ 12,565.35
Revised Contract Amount	\$1,317,422.53
Percent increase from original contract	7%

BUDGET IMPACT:

The fiscal year 2022-23 budget includes \$1,000,000 from CFD 2013-1 for the Mutual Well #7 Well Equipment and Piping project.

Attachment: Change Order No. 4



CHANGE ORDER #4

June 29, 2022

PROJECT: Mutual Well #7 Well Equipment and Site Work Specification 20-438
CONTRACTOR: Travis Agricultural Construction, Inc.
ADDRESS: P.O. Box 4666, Ventura, CA 93007

ITEM	DESCRIPTION OF WORK	TOTAL
1	Cost associated with well casing modifications for procurement of stainless steel casing and accessory tubes extensions.	\$ 12,565.35

TOTAL AMOUNT OF CHANGE ORDER NO. 4	<u>\$ 12,565.35</u>
ORIGINAL CONTRACT AMOUNT	<u>\$ 1,232,667.00</u>
PREVIOUS APPROVED CHANGE ORDER AMOUNT	<u>\$ 72,190.18</u>
NEW CONTRACT AMOUNT	<u>\$ 1,317,422.53</u>
EXTENSION OF CONTRACT TIME <u>-0-</u> DAYS	

CASITAS MUNICIPAL WATER DISTRICT

By: _____
 MICHAEL L. FLOOD
 GENERAL MANAGER

DATE: _____

TRAVIS AGRICULTURAL CONSTRUCTION, INC.

By: _____

DATE: _____

T · R · A · V · I · S

Rex Bartle



CONTRACT CHANGE ORDER #4 (07/08/22)

THIS AGREEMENT IS BETWEEN:

RE: PROJECT: CMWD Mutual Well #7 E-21964

TRAVIS AGRICULTURAL CONSTRUCTION, INC.

CASITAS MUNICIPAL WATER DISTRICT

(Contractor's Name)

(Owner's Name)

#588676-HAZ

1055 Ventura Ave.

(Contractor's License Number)

(Owner's Address)

P.O. Box 4666

Oak View, CA 93022

(Contractor's Address)

(City, State, & Zip)

Ventura, CA 93007

1055 Ventura Ave.

(City, State & Zip)

(Project Address)

(805) 647-7211 / (805) 647-3423 fax

Oak View, CA 93022

(Telephone / Fax)

(City, State & Zip)

CHANGE ORDER #4:

This Change Order (CO) #4 is to provide stainless steel materials to extend the well casing and accessory tubes 2-ft above ground surface.

NOTE: Carbon steel materials previously ordered apart from this change order will be delivered to the site at time of installation.

<u>Revised</u> Subcontractor's Contract Amount (04/14/2022)	\$353,554.95
Subcontractor's Lump Sum CO#4 Labor & Materials	\$11,967.00

Shop & Field Labor:

- Shop and Field preparation for stainless steel materials installation
- Load/Unloading of stainless-steel materials

Materials:

- 36" x 36" x 1-1/4" Thick 304L Stainless Steel Sole Plate Sq (per attached drawing)
- 14-1/4" OD x 3/8" Wall Thickness x 2 ft long 304L Stainless Steel Casing Material
- 2" Sch40 304L Stainless Steel Pipe Material (Qty 2)
- 3" Sch40 304L Stainless Steel Pipe Material (Qty 1)
- Misc. consumables materials, bolting, tape & banding
- Estimated Freight

CO#4 Subcontractor's Total Cost	\$11,967.00
Markup 5%	\$ 598.35
Total Amount CO#4	\$12,565.35

Original Subcontractor's Amount	\$198,731.40
Revised Subcontractor's Amount (04/14/2022)	\$353,554.95
<u>ADD CO#4 Total Amount</u>	<u>\$ 12,565.35</u>
New Subcontractor's Amount (06/29/2022)	\$366,120.30

Total CO#4 Increase Amount **\$12,565.35**

It is mutually agreed that the contract price has an **increase** of **\$12,565.35 payable** per contract terms. As a result of this change order, the time for completion of the above-mentioned contract is TBD. This change order is incorporated into and governed by the above-mentioned contract and is incorporated therein. Please expedite the reviewal of this change order as the lead time for materials is 2 weeks upon change order and submittal approval.

Travis Ag Construction/Date

Casitas Municipal Water District /Date



159 N. ACACIA STREET * SAN DIMAS, CA 91773
PHONE: (909) 599-9606 * FAX: (909) 599-6238

CAMARILLO, CA 93010 * PHONE: (805) 482-1215
www.genpump.com

WELL & PUMP SERVICE SINCE 1952

Lic. #496765

Serving Southern California and Central Coast

Travis Ag Construction Inc.
P.O. Box 4666
Ventura, CA 93007
Attn: Earwin Bihis

July 8, 2022

Subject: CMWD Ojai Mutual #7 – Change Order #4 SS Casing Extension

General Pump Company is pleased to provide our estimate to provide stainless steel materials and personnel to extend the well casing and accessory tubes 2 ft above ground surface for Ojai Mutual Well No. 7. Note, the carbon steel materials previously ordered apart of this project will be delivered to the site at time of installation.

This does not include the time and materials which was spent for Travis Ag personnel onsite previously.

Shop & Field Labor:

- Load/Unloading of stainless steel materials
- Shop and Field Preparation of stainless steel materials

Materials:

- 36" x 36" x 1-1/4" Thick 304L Stainless Steel Sole Plate Sq (per attached drawing)
- 14-1/4" OD x 3/8" Wall Thickness x 2 ft long 304L Stainless Steel Casing Material
- 2" Sch40 304L Stainless Steel Pipe Material (Qty 2)
- 3" Sch40 304L Stainless Steel Pipe Material (Qty 1)
- Misc. consumables materials, bolting, tape & banding
- Estimated Freight

Total Lump Sum Change Order #1 Cost \$11,967.00

Material lead time is approximately 1-2 week. Should you have any questions, please do not hesitate to contact us. Thank you.

Sincerely,

GENERAL PUMP COMPANY, INC.

Luis Busso
Luis Busso, P.G.
Sr. Project Geologist

Ray Reece
Ray Reece
General Manager

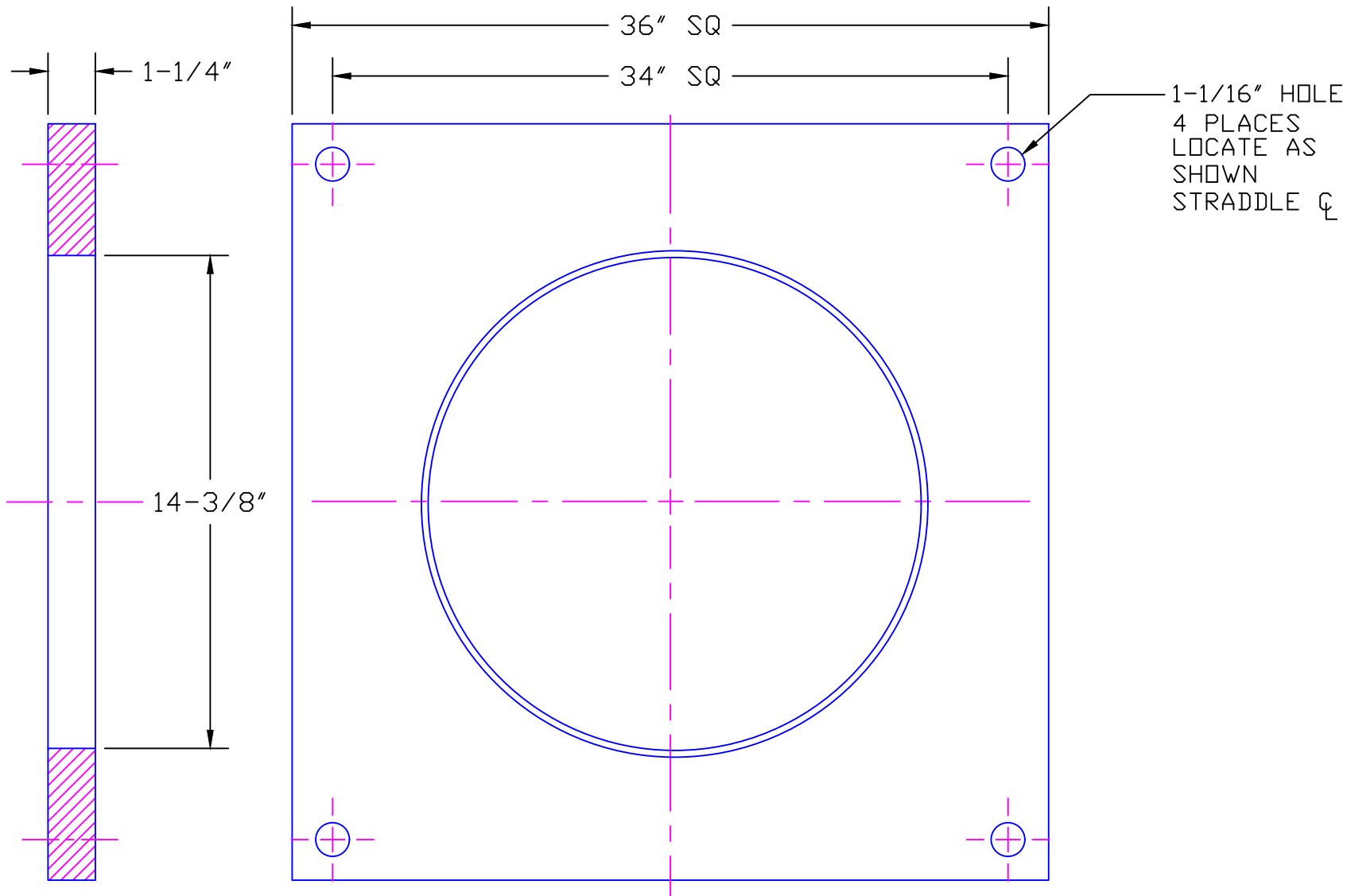

<p>TOLERANCES EXCEPT AS NOTED: DECIMALS: .000 = ± .010 .00 = ± .032 .0 = ± .062 ANGLES: ± 1/4 DEGREE SQUARENESS: MACHINED FACES MUST BE PARALLEL WITH EACH OTHER AND PERPENDICULAR TO MACHINED DIAMETERS WITHIN .002 T.I.R. BREAK ALL SHARP EDGES .015 - .030</p>	 <p>159 North Acacia Street San Dimas, Ca 91773 Phone: (909) 599-9606 Fax: (909) 599-6238</p>	<p>GENERAL PUMP COMPANY WATERWELL & PUMP SERVICE SINCE 1952</p>		
		<p>CUSTOMER : CASITA MWD - WELL NO.7</p>		
		<p>DESCRIPTION : 1.25" THK. x 36" SQUARE PLATE</p>		
		<p>MATERIAL : 304L STAINLESS STEEL</p>	<p>DWG NO. 81285-SP</p>	
<p>PCS. REQ'D : ONE</p>	<p>GPC ENGINEERING</p>	<p>BY: LUIS</p>	<p>DATE: 06/22/2022</p>	<p>JOB 81285</p>

**CASITAS MUNICIPAL WATER DISTRICT
MEMORANDUM**

TO: BOARD OF DIRECTORS
FROM: MICHAEL FLOOD, GENERAL MANAGER
SUBJECT: AMENDMENTS TO PROFESSIONAL SERVICES AGREEMENTS FOR VENTURA-SANTA BARBARA COUNTIES INTERTIE
DATE: 07/13/2022

RECOMMENDATION:

- Approve and amend the agreement for professional environmental consulting services with Rincon Consultants, Inc., for the Ventura-Santa Barbara Counties Intertie for a fee increase not to exceed \$24,158.00 for a total fee of \$267,886.00.

BACKGROUND AND DISCUSSION:

The Ventura-Santa Barbara Counties Intertie project includes approximately 8,200 feet of 16-inch pipeline and a two booster pump stations to connect the Carpinteria Valley Water District (CVWD) and Casitas systems. The Board approved an agreement with Rincon Consultants, Inc. (Rincon) in March 2019 in the amount of \$98,559 to provide environmental consulting services, including the preparation of an Initial Study-Mitigated Negative Declaration (IS-MND) in compliance with the California Environmental Quality Act (CEQA). The following amendments were previously approved:

Amendment No.	Date Approved	Scope	Fee
1	07/10/2019	Revisions to the pipeline alignment, additional pump station, and additional meetings and coordination for grant application assistance	\$35,007
2	11/12/2020	Regulatory permitting assistance and Federal cross-cutting requirements	\$51,574
3	05/18/2021	Analysis of potential BPS-B site	\$5,233
4	10/13/2021	Revisions to design including BPS-B, pressure reducing facility,	\$53,355

The total contract to date is \$243,728.

The Public Draft IS-MND was released for public comment on March 29, 2021. The IS-MND was not adopted by the Board as it became apparent the design changes necessitated revision to the IS-MND and re-release for public review and comment.

Rincon has submitted an amendment request in the amount of \$24,158 to update the IS-MND document with the identified design changes and updated environmental assessments to meet funding requirements. The changes to be incorporated in the revised IS-MND are reflected in Rincon's scope of work attached. This amendment increases the total budget for Rincon's

services from \$243,728 to \$267,886. It is anticipated the revised IS-MND will be prepared in approximately three months. After the public review period of 30 days, it is expected the Board would adopt the IS-MND in January 2023.

BUDGET IMPACT:

The budget for fiscal year 2022-23 includes \$1,500,000 for the project, which is anticipated to be sufficient for expenditures this fiscal year.

Attachments:

- Amendment Request No. 5 from Rincon Consultants dated July 7, 2022
- Amendment No. 5 Environmental Consulting Services, Rincon Consultants, Inc.



Rincon Consultants, Inc.

180 North Ashwood Avenue
Ventura, California 93003

805 644 4455 OFFICE AND FAX

info@rinconconsultants.com
www.rinconconsultants.com

July 7, 2022

Project No: 19-07446

Julia Aranda, Engineering Manager
Casitas Municipal Water District
1055 Ventura Avenue
Oak View, California 93022
Via email: jaranda@casitaswater.com

Subject: Amendment No. 5 to Provide Environmental Consulting Services for the Ventura-Santa Barbara Counties Intertie Project

Dear Ms. Aranda:

The purpose of this letter is to request a revised scope and budget amendment to the existing agreement for the Ventura-Santa Barbara Counties Intertie Project (project) between Casitas Municipal Water District (Casitas) and Rincon Consultants, Inc. (Rincon). On March 27, 2019, an original contract was executed in the amount of \$98,559. On July 10, 2019, Amendment No. 1 was executed, increasing the total contract to \$133,566. On November 12, 2020, Amendment No. 2 increased the total contract amount to \$185,140. On May 18, 2021, Amendment No. 3 increased the total contract amount to \$190,373. On October 13, 2021, Amendment No. 4 increased the total contract amount to \$243,728.

This Amendment No. 5 is intended to address additional effort needed to revise the Public Review Draft IS-MND for recirculation due to changes made to the project description after the original public review period.

Understanding of the Project

The Ventura-Santa Barbara Counties Intertie Project Public Review Draft IS-MND was circulated for public review from April 2 to May 2, 2021. Since then, changes have been made to the project description, including:

- Removal of the previously identified site options for Booster Pump Station A (BPS-A) and Booster Pump Station B (BPS-B), and addition of new BPS-A and BPS-B site locations and staging areas;
- Relocation of western portion of Pipeline Segment 3B;
- Selection of the preferred engineering alternative for the pipeline alignment across Rincon Creek (Segments 1, 2B, and 3B [as adjusted] from the previously circulated Draft IS-MND);
- Minor improvements at the Rincon Control Reservoir, Rincon Pump Plant, Balancing Tanks, and the Rincon Vents off Lake Casitas Fire Road; and
- Addition of up to five new pipeline rehabilitation sites, which would involve temporary construction pits measuring approximately 400 square feet each.



The newly proposed project components were not analyzed in the previously circulated Public Review Draft IS-MND. As such, additional work is needed to revise the Public Review Draft IS-MND and technical reports for recirculation.

In addition, Rincon understands Casitas may pursue new sources of funding for the project, including federal sources such as the State Water Resources Control Board (SWRCB) Clean Water State Revolving Fund (SRF) Program or the Federal Emergency Management Agency (FEMA) Building Resilient Infrastructure and Communities (BRIC) Program. Rincon also understands the project will require approval of the United States Bureau of Reclamation (BOR). As such, additional work is needed to update the federal environmental cross-cutter analyses prepared for the original Administrative Draft IS-MND in 2019. We understand the BOR will likely be the lead agency under the National Environmental Policy Act (NEPA). The BOR will prepare necessary NEPA documentation, which it believes will include a Categorical Exclusion.

Revised Scope of Work

The revised scope of work includes the following tasks and builds on existing Tasks 1 through 13 in our currently authorized scope of work. This amendment accounts for additional work needed to complete biological and cultural field reconnaissance surveys of the new project locations, as well as work needed to revise the Public Review Draft IS-MND and technical reports for recirculation.

Rincon's Amendment Request No. 3, dated May 18, 2021, included scope and budget for updates to the federal environmental cross-cutter analyses. As discussed after contract execution, because the Additional Supplemental Appropriation for Disaster Relief Act (ASADRA) program exempted funded projects from federal environmental cross-cutter analyses, Rincon did not update the federal cross-cutter analyses and instead pivoted to use this budget for unanticipated additional effort associated with the Notice of Intent (NOI), circulation of the Public Review Draft IS-MND, and coordination required in response to public comments received. As such, this Amendment Request No. 5 includes scope and budget to update the federal environmental cross-cutter analyses to support future federal funding pursuits.

Task 1. Project Initiation

The project initiation task has been completed.

Task 2. Biological Resources Assessment

The Biological Resources Assessment (BRA) was originally completed in July 2019. The SRF Program requires United States Fish and Wildlife Service (USFWS) species lists in biological reports be less than one year old. The species list in the Biological Resources Assessment is dated May 2019. Therefore, Rincon will acquire an updated species list for the project area and update the Biological Resources Assessment accordingly. In addition, new project components have been added to the project area. Under this revised task, Rincon will implement the following subtasks.



Subtask 2.1. Literature/Database Research

Rincon will update the literature/database review of the California Department of Fish and Wildlife (CDFW) California Natural Diversity Database, CDFW Biogeographic Information and Observation System, California Native Plant Society Online Inventory of Rare and Endangered Plants, and USFWS Critical Habitat Portal. In addition, an official species list from the USFWS Information for Planning and Consultation (iPaC) tool will be obtained, reviewed, and included as an appendix to the revised report (Subtask 2.3). We will also review other resources which may have been updated, including, but not limited to, aerial photographs, topographic maps, and other and available aquatic resources information.

Subtask 2.2. Field Survey

Following the literature/database review, a qualified Rincon biologist will conduct a field survey of the new project areas to confirm and/or update any biological conditions which may have changed since the previous surveys. The survey will include the new project areas as well as a 200-foot buffer where accessible. Areas which are inaccessible (e.g., private property) will be surveyed via binoculars from accessible areas. The survey will assess the potential presence of special-status biological resources, including plant and wildlife species, plant communities, jurisdictional waters and wetlands, and suitable habitat for nesting birds. The identification of potential special-status species' habitat is based on a suitability analysis level only and does not include definitive surveys for the presence or absence of the species which may be present, including, but not limited to, California red-legged frog, legless lizard, and monarch butterfly. The field survey will be conducted by one biologist surveying for up to two 8-hour days, including drive time. This scope of work does not include species-specific surveys. However, if Rincon biologists determine certain special-status plant or wildlife species surveys are required, we will contact Casitas staff immediately. Additional surveys will require an amendment to the scope of work and cost for this project. It is noted such species-specific survey protocols may require extensive field survey time to be conducted only at certain times of the year.

Subtask 2.3. Biological Resources Assessment Update

Based on the results of the literature/database research and field survey, Rincon will update the findings of the 2019 BRA. The BRA will include the following information:

- Project/construction footprint description
- Survey area description and survey methodology
- Biological inventory
- Physical site characteristics (topography, soil, drainages)
- Vegetation community classifications and mapping
- Plant and wildlife species observed on site
- Identification and analysis of special-status species observed or expected
- Nesting bird habitat assessment
- Wildlife movement evaluation
- General protected tree assessment
- Potential jurisdictional areas evaluation



- Impact assessment
 - Special-status species tables which provide the current status of each species identified, habitat requirements, and the potential for occurrence within or near the project limits
 - Comparison of the impacts which would result from the proposed project-related activities with identified special-status habitats and/or species, jurisdictional areas, protected trees, wildlife movement, and nesting birds
- Recommendations to avoid and/or minimize impacts to protected biological resources and identification of mitigation measures to mitigate impacts to regulated biological resources which cannot be avoided or minimized
- Photo-documentation of the existing site conditions
- Graphics depicting site location, habitats, potential jurisdictional areas, and special-status species (if found)

An electronic draft version of the report will be submitted to Casitas for review. Rincon assumes one round of comments will be necessary. It is also assumed comments will be provided in a consolidated and electronic, editable format. Once reviewed, digital copies of the final report will be prepared and submitted. All deliverables will be digital; no printing or shipping costs are included.

Task 3. Cultural Resources Technical Study

The California Office of Historic Preservation generally recommends cultural resources investigations be updated every five years. Because the previous cultural resources technical study was completed between May 2019 and February 2021, much of the previously prepared analysis remains valid. However, due to the new project elements, some areas of the previous study will need to be supplemented as detailed below.

Rincon understands the project has a federal nexus and therefore will be subject to Section 106 of the National Historic Preservation Act (Section 106). A combined cultural resources technical study will be completed to meet both federal and State regulations. The Area of Potential Effects (APE) map will be updated to include the new project areas; Rincon assumes the APE will be limited to the direct footprint based on our experience and the nature of the project. A supplemental records search of the California Historical Resources Information System (CHRIS) will also be required to capture areas which were not covered in the previous study. Those areas which will require a supplemental CHRIS search appear to be located within Ventura County and therefore the search will be completed by staff at the South Central Coastal Information Center at California State University, Fullerton. The search will include the new project sites plus a 0.5-mile buffer and is not anticipated to exceed \$750 inclusive of direct expenses and associated fees. Section 106 consultation will also be updated to include outreach to local Native American tribes and individuals, and local historical interest groups and governments as appropriate. A cultural resources field survey will then be completed to survey new project areas. Rincon assumes the survey will not exceed one 8-hour day and will be completed by one cultural resources specialist. Rincon also is aware of two built environment structures, two water tanks, and a chlorination facility which are of age and will require evaluation for the California Register of Historical Resources and the National Register of Historic Properties. Rincon assumes the project will not involve improvements to the Casitas Dam which would require an evaluation of eligibility or updated documentation. Rincon will subsequently update the cultural resources technical report to include the supplemental background research and survey results.



An electronic draft version of the report will be submitted to Casitas for review. Rincon assumes one round of comments will be necessary. It is also assumed comments will be provided in a consolidated and electronic, editable format. Once reviewed, digital copies of the final report will be prepared and submitted. All deliverables will be digital; no printing or shipping costs are included.

Task 4. Paleontological Resources Assessment

The Paleontological Resources Assessment will be updated to account for the revised project description. Rincon assumes no fieldwork will be necessary to complete this task. Rincon will conduct a paleontological resources assessment to identify the geologic units which may be impacted by project development, determine the paleontological sensitivity of geologic unit(s) within the revised project site, assess potential for impacts to paleontological resources from development of the proposed project, and recommend mitigation measures to avoid or mitigate impacts to scientifically significant paleontological resources. The updated paleontological resource assessment will be designed to support applicable environmental review and consist of reviewing existing geologic maps, searching online museum databases (e.g., University of California Museum of Paleontology), and examining primary literature regarding fossiliferous geologic units within the project vicinity and region.

A paleontological locality search of United States Geological Survey 7.5-minute topographic map White Ledge Peak was conducted to complete the original assessment. The latest revisions to the project area exceed the boundary of this quadrangle. Due to the project area revisions exceeding the boundary of the White Ledge Peak quadrangle and extending into two other quadrangles (Matilija and Ventura), this amendment will include a records search for these two additional quadrangles.

Rincon will provide the results of the paleontological resources impact analysis in a standalone memorandum which will be appended to the revised IS-MND. The memorandum will discuss the results of the literature review and additional records search, provide a discussion of the regional geology and the geologic unit(s) present within the project site, characterize the paleontological sensitivity of the geologic units present within the project site using the Society of Vertebrate Paleontology's paleontological sensitivity classification system, assess the potential for significant impacts to scientifically important paleontological resources under federal and State guidelines, and provide management recommendations for avoiding or reducing impacts to paleontological resources from project development as necessary.

Task 5. Administrative Draft IS-MND

The Administrative Draft IS-MND has been completed. No changes are proposed to this task.

Task 6. Public Review Draft IS-MND

Rincon will revise the Public Review Draft IS-MND to account for the revised project description. This task will include revising the environmental impacts analysis in the Public Review Draft IS-MND. The revised Public Review Draft IS-MND will include changes based on work completed under Tasks 2 through 4 above. Rincon will also revise the responses to other environmental resource topics as applicable.

In addition, Rincon will incorporate revisions to address public comment letters received during the original public review period. We assume Rincon will respond to one round of electronic comments from Casitas on a Microsoft Word version of the Public Review Draft IS-MND. An electronic PDF version will be submitted to Casitas for final approval. This scope of work and cost estimate do not include providing



documents which are accessible pursuant to the Americans with Disabilities Act (ADA) or printed copies. However, accessible documents and/or printed copies can be provided for an additional fee, if needed. Rincon will provide a PDF electronic version for posting on Casitas' website and submit the document to the State Clearinghouse on behalf of Casitas. Rincon will also distribute a Notice of Intent (NOI) to Adopt an MND to up to 20 mailing addresses and file the NOI with the Ventura and Santa Barbara County Clerks. We assume Casitas will be responsible for publishing the notice in a local newspaper(s) and/or noticing via direct mailing to the owners and occupants of property contiguous to the project site, as well as payment of required County Clerk filing fees; however, if desired, Rincon can coordinate such noticing at an additional cost.

Task 7. Final IS-MND

No changes to the authorized scope of work are proposed to this task. The text below has been provided to reiterate Rincon's outstanding scope from our current contract.

Upon receipt of public comments on the Draft IS-MND, Rincon will prepare draft responses to comments and the administrative Final IS-MND for Casitas review. We assume there will be moderate public comments on the Draft IS-MND based on the comments received during the public comment period on the original Draft IS-MND. However, if there is a substantial number of comments requiring a response, a budget amendment may be required. Rincon will also prepare the Mitigation Monitoring and Reporting Program (MMRP). The MMRP will list in tabular format the mitigation measures and corresponding monitoring requirements, the entities responsible for monitoring and completing the mitigation, and schedule for mitigation implementation.

Rincon will provide the administrative Final IS-MND (including draft responses to public comments and the MMRP) in electronic format for Casitas review. Rincon will revise the Final IS-MND based on one round of consolidated comments from Casitas to be provided in an electronic, editable format. Rincon will then provide electronic versions of the Final IS-MND to Casitas for distribution. Upon adoption of the Final MND and approval of the project, Rincon will prepare and file with the State Clearinghouse and County Clerks the Notice of Determination (NOD). We assume Casitas will be responsible for paying applicable filing fees. We can coordinate payment of the required fees, if desired, pursuant to written authorization to invoice the fee amounts. Printed copies of the Final IS-MND can be provided at an additional cost upon request.

It is noted this scope of work and cost estimate do not include providing documents which are ADA accessible pursuant to the. However, accessible documents can be provided for an additional fee, if needed.

Task 8. Regulatory Permitting

In addition to the original scope of work for Task 8, this task has been revised to include a meeting with Casitas to discuss the various options and strategies available to Casitas for proceeding with regulatory permitting strategies for the project. Rincon staff will review available project information and attend a one-hour meeting with Casitas to discuss a permitting strategy.

In addition to the regulatory permits originally anticipated to be necessary for the proposed project, a Coastal Development Permit (CDP) from the County of Santa Barbara will be needed for construction activities resulting in more than 50 cubic yards of cut soil. The proposed Check Valve Removal south of Lillingston Canyon Road may be exempt under the Article II, Appendix B of the Operations and



Maintenance Regulations if work can be completed by hand without excavation; however, the remainder of the trenching work would require a permit from the County of Santa Barbara. Casitas will also need to obtain an Encroachment Permit from the California Department of Transportation (Caltrans) before the CDP can be issued. Rincon assumes a CDP is not warranted for proposed work in Ventura County since proposed ground disturbance in Ventura County will not occur within the Coastal Zone. This scope of work and cost estimate do not include assistance for obtaining a CDP or the associated Caltrans Encroachment Permit. However, Rincon can provide such assistance for an additional fee.

Task 9. Federal Clean Air Act Conformity Applicability Analysis

Rincon will update the air pollutant emissions modeling in the California Emissions Estimator Model to account for the changes to the project description. Rincon will notify Casitas immediately if the modeled emissions require mitigation to reduce potential impacts to a less-than-significant level.

Task 10. Public Meeting/Hearing

No changes are proposed to this task. The text below has been provided to reiterate Rincon's outstanding scope from our current contract.

Rincon's Project Manager and/or Principal-in-Charge will attend one virtual public meeting or hearing related to the IS-MND. Attendance will include an oral presentation, if requested by Casitas. If needed, Rincon will attend additional meetings or hearings on a time-and-materials basis, in accordance with our standard fee schedule.

Task 11. Project Management

Project management tasks include in-house management of Rincon staff during the remainder of this scope of work, responding to telephone calls and emails regarding the project, monitoring the project budget and schedule, and other similar tasks. This task includes attendance by up to two Rincon staff at the one-hour bi-weekly meetings. This task assumes seven additional months of project management time due to the lengthened project schedule.

Task 12. AB 52 Consultation Assistance

Under Assembly Bill (AB) 52, Casitas, as the CEQA lead agency, is required to begin consultation with California Native American tribes traditionally and culturally affiliated with the project area prior to the release of a negative declaration, mitigated negative declaration, or environmental impact report. Although this consultation was previously completed, changes to the project necessitate AB 52 consultation be updated. Rincon will request an updated AB 52 consultation list from the Native American Heritage Commission on behalf of Casitas, should Casitas choose to request such a list. Rincon will assist Casitas with consultation under AB 52 by providing Casitas with letter templates, checklists, and detailed instructions to ensure meaningful consultation with interested Native American groups can be completed in accordance with AB 52. This task does not include costs for meetings, outreach, or additional consultation by Rincon or the mailing of any letters to tribal governments. Rincon can assist with these tasks for an additional cost. Rincon will incorporate the results of AB 52 consultation into the Tribal Cultural Resources section of the IS-MND.



Task 13. Biological Resources Scoping Visit

No changes are proposed to this task, as the biological resources scoping visit has been completed.

Assumptions

Rincon has made the following assumptions in developing the scope of work for the revised proposed project:

- Complete site plans in portable document format (PDF) and Geographic Information System (GIS) or a georeferenced AutoCAD format will be provided prior to initiation of database/literature review and field work.
- Rincon will be provided safe access and full right of entry to all portions of the project site prior to conducting fieldwork.
- The additional surveys for biological and cultural resources will include the new project areas illustrated in the KMZ file from WaterWorks Engineers, as confirmed by Julia Aranda on June 27, 2022, as well as an appropriate buffer where accessible.
- Rincon assumes one round of revisions by Casitas will be needed for each document in this scope of work. If additional revisions are needed, they can be completed under an expanded scope and cost.
- In light of the current COVID-19 pandemic, Rincon staff will conduct the scope of work in accordance with the latest relevant, local COVID-19 safety protocols and social distancing guidance. Should safety protocols and social distancing guidance change during Rincon's authorized activities so they may affect the schedule or cost, we will consult with Casitas on next steps and the potential need to adjust the scope and budget.

Cost Estimate

Our cost estimate for the additional scope of work described above is **\$24,158**, increasing the total contract amount from \$243,728 to **\$267,886**. This requested budget increase takes into account Rincon's current remaining authorized budget for the project. The table at the end of this letter shows a breakdown of costs by task. It is noted the current remaining labor budgets for Tasks 4, 8, and 9 are sufficient to complete the additional scope of work included in this amendment. Cost estimates are based on the agreed upon fee schedule for our On-Call Environmental Services FY 2022-23 contract executed on June 22, 2022; it is noted use of the On-Call contract fee schedule results in a savings of approximately five percent when compared to our current standard fee schedule. The cost table is provided as an estimate of Rincon's effort per task. Rincon may reallocate budget between staff and tasks, as long as the total contract price is not exceeded.



Closing

This proposal is valid for a period of 60 days and is fully negotiable to meet the needs of Casitas. We appreciate the opportunity to continue to assist Casitas with this project. Please let us know if you have questions regarding this proposal.

Sincerely,
Rincon Consultants, Inc.

A blue ink signature of Melissa J. Whittemore, consisting of a series of loops and a long horizontal stroke.

Melissa J. Whittemore
Supervising Environmental Planner

A blue ink signature of Jennifer Haddow, PhD, featuring a large 'J' and 'H' followed by a horizontal line.

Jennifer Haddow, PhD
Vice President



RINCON CONSULTANTS, INC.
 Ventura-Santa Barbara Counties Intertie Project

Environmental Services Program

Tasks	Labor	Direct Expense	Budget
Task 1. Project Initiation			
Task 2. Biological Resources Assessment	\$4,662	\$286	\$4,948
Task 3. Cultural Resources Technical Study	\$3,896	\$1,003	\$4,899
Task 4. Paleontological Resources Assessment		\$345	\$345
Task 5. Administrative Draft IS-MND			
Task 6. Public Review Draft IS-MND	\$4,236	\$200	\$4,436
Task 7. Final IS-MND			
Task 8. Regulatory Permitting			
Task 9. Federal Clean Air Act Conformity Analysis			
Task 10. Public Meeting/Hearing			
Task 11. Project Management	\$8,960		\$8,960
Task 12. AB 52 Consultation Assistance	\$570		\$570
Task 13. Biological Resources Scoping Visit			
TOTAL PROJECT BUDGET	\$ 22,324	\$ 1,834	\$ 24,158

Direct Cost Summary

Vehicle Costs	\$ 264
Standard Field Package	\$ 220
Printing	\$ 60
Postage	\$ 140
Records Searches	\$ 1,150
Subtotal Additional Costs	\$ 1,834



AMENDMENT NO. 5

ENVIRONMENTAL CONSULTING SERVICES WITH

RINCON CONSULTANTS, INC.

FOR VENTURA-SANTA BARBARA COUNTIES INTERTIE

This Amendment No. 5 to Agreement for Environmental Consulting Services is made and entered into as of this 13th day of July, 2022 ("Effective Date") by and between Casitas Municipal Water District (Casitas or District) and Rincon Consultants, Inc. (Consultant) whose address is 180 N Ashwood Avenue, Ventura CA 93003, and is made with reference to the following:

RECITALS

- A. On March 27, 2019, District and Consultant entered into a Professional Services Agreement (Agreement) for environmental consulting services for the Ventura-Santa Barbara Counties Intertie project (Project).
- B. On July 10, 2019, District and Consultant executed Amendment No. 1 to the Agreement.
- C. On November 12, 2020, District and Consultant executed Amendment No. 2 to the Agreement.
- D. On May 18, 2021, District and Consultant executed Amendment No. 3 to the Agreement.
- E. On October 13, 2021 District and Consultant executed Amendment No. 4 to the Agreement.
- F. District desires to enter this Amendment No. 5 to reflect additional services not included in the Agreement, Amendment No. 1, Amendment No. 2, Amendment No. 3, nor Amendment No. 4 to extend the term of the Agreement to June 30, 2023, and to increase the total compensation.
- G. District and Consultant mutually desire to amend the Agreement as provided below.

NOW, THEREFORE, it is mutually agreed by and between the undersigned parties as follows:

1. SCOPE OF SERVICES

Section 3 of the Agreement shall be supplemented to include Amendment Request No. 4 to Provide Additional Environmental Consulting Services for the Ventura – Santa Barbara Counties Intertie Project dated August 26, 2021, which is attached hereto as Exhibit A and incorporated herein by reference.

2. FEE FOR SERVICES

The second paragraph of Section 4 shall be replaced in its entirety with the following: The total fee for services shall not exceed \$267,886.00 without prior written consent of the District.

3. INTEGRATED CONTRACT

Except as expressly modified herein, all other provisions, terms, and covenants set forth in the Agreement shall remain unchanged and shall be in full force and effect.

IN WITNESS WHEREOF, the parties have caused this Amendment to be executed on the day and year first above written.

ATTEST:

CASITAS MUNICIPAL WATER DISTRICT

By: _____

Secretary
Casitas Municipal Water District

Casitas Municipal Water District

APPROVED AS TO FORM:

John M. Mathews, Attorney
Arnold La Rochelle Mathews VanConas & Zirbel, LLC

RINCON CONSULTANTS, INC.

By: _____

Title: _____

Printed Name: _____

**CASITAS MUNICIPAL WATER DISTRICT
MEMORANDUM**

TO: BOARD OF DIRECTORS
FROM: MICHAEL L. FLOOD, GENERAL MANAGER
SUBJECT: **CONSIDERATION AND POSSIBLE ACTION ON A TERM SHEET FROM UNITED WATER CONSERVATION DISTRICT REGARDING A FIVE-YEAR TRANSFER OF CASITAS MWD'S STATE WATER PROJECT TABLE A WATER SUPPLY.**
DATE: 07/08/2022

RECOMMENDATION:

Direct staff to bring back the 'definitive agreement' for further consideration.

BACKGROUND:

Casitas currently holds the rights to 5,000 Acre-Feet of State Water Project (SWP) Table A water supply allocation.

Casitas currently has no ability to deliver its SWP Table A water supply allocation into its service area.

Casitas is currently considering projects that would construct conveyance facilities to allow Casitas the ability to deliver imported water to its service area, but these projects are not expected to be complete for approximately four years.

In recent years, Casitas has executed exchange and transfer agreements with other agencies who have the ability to receive imported water, including San Geronio Pass Water Agency and Central Coast Water Authority.

On March 9, 2022, the Casitas Board directed staff to begin discussions with United Water Conservation District (United) on a term sheet for a five-year transfer of Casitas MWD's State Water Project Table A supplies for the five calendar years of 2023 through 2027.

On June 8, 2022, the Casitas Board directed staff to sign a letter of intent to negotiate with United Water Conservation District over the next ninety days an agreement for a multi-year transfer of Casitas MWD's State Water Project Table A supplies for up to five calendar years of 2023 through 2027.

DISCUSSION:

Casitas and United staff have been in discussions regarding a draft term sheet over the last thirty days.

The current draft term sheet is attached that United staff expects to bring to the United Board of Directors.

Summary of Draft Terms:

- Five-year term (2023-2027) with years three through five optional.
- Transfer of 100% of Casitas' State Water Project Table A allocation.
- Transfer of 100% of Casitas' State Water Project Article 21 allocation (if any).
- Rights to the use of Casitas' State Water Project storage and conveyance capacities related to the transferred water supplies.
- Pricing on a sliding scale based on the SWP Table A allocation in a given year (see Exhibit A).
- United to pay all variable costs related to the transferred water supply.
- United will be forbidden to transfer/sell any water supplies transferred under this agreement by Casitas.
- A 'definitive agreement' will contain further details of the proposed transaction and will need to be approved by both elected Boards (Casitas and United).
- CEQA compliance to be prepared in conjunction with the 'definitive agreement'.

Casitas staff expects to return with the 'definitive agreement' along with any needed CEQA compliance actions in the next few months.

**TERM SHEET FOR MULTI-YEAR WATER TRANSFER PROGRAM BETWEEN
CASITAS MUNICIPAL WATER DISTRICT
AND
UNITED WATER CONSERVATION DISTRICT**

1. Recitals

- a. Casitas Municipal Water District (“Casitas”) and the United Water Conservation District (“United”) each have water supply contracts, indirectly, with the California Department of Water Resources (“DWR”) for water from the State Water Project (“SWP”).
- b. Ventura County Watershed Protection District (VCWPD) is the named contractor with the State of California for 20,000 acre feet of Table A water.
- c. Casitas is the administrator of the Water Supply Contract and has retained access to 5,000 acre feet of the total 20,000 acre feet of Table A Water.
- d. Casitas is presently unable to directly deliver SWP supplies into its service area.
- e. United also has subcontracted with Casitas for access to 5,000 acre feet of SWP Table A.
- f. Without local conveyance facilities in place to currently utilize SWP water, Casitas believes it could benefit from a water transfer that delivers its Table A water to others to provide an offset of costs related to imported water supplies.
- g. Casitas is considering options to obtain its SWP water in the future through exchange or physical connection. An interconnection will still require between three and five years to implement.
- h. United is willing to purchase Casitas’ allocated Table A water supply and take delivery of the additional water in its service area.
- i. United needs additional water within the United’s service area due to reduced diversions at the Freeman Diversion as a direct result of NMFS’ mandated environmental bypass flows for steelhead trout.
- j. United and Casitas recognize that the allocation of Table A water varies from year to year and that Article 21 water allocations are very intermittent and sporadic.
- k. United has a variety of water delivery opportunities including groundwater recharge and banking programs. United is well positioned to utilize water made available on an irregular basis.
- l. Therefore, Casitas and United propose to initiate a multi-year Water Transfer Program (“Program”) for their mutual benefit and better water management of their SWP water and other supplies.
- m. The proposed multi-year agreement will cover five calendar years.

- n. Casitas desires the flexibility to withdraw from the agreement in the third, fourth and/or fifth year in the event that Casitas has the need to deliver these supplies to meet its customer demands.
- o. This term sheet will be followed by a ‘definitive agreement’ that will contain the tenets of this term sheet for review and approval by Casitas and United.

2. Term of Agreement

- a. The agreement term will be from the date executed by both parties until December 31, 2027, unless extended by mutual agreement.
- b. Parties may terminate the agreement at any time by mutual consent.
- c. Casitas will retain the ability to terminate this Agreement in the year 2025, 2026, or 2027 if a temporary or permanent project allowing for the direct delivery of SWP to Casitas’ service area is made available.

3. Quantity of Water Transferred

- a. It is understood that the Table A allocation refers to the Casitas’ SWP Table A allocation.
- b. Starting in the year 2023, United is entitled to purchase all of Casitas’ allocated Table A water throughout the term of the agreement, which would expire on December 31, 2027 or earlier, or may be extended, by mutual consent.
- c. Allocations by the DWR of SWP water typically begin on December 1 of each year for the following calendar year. The allocations by DWR are generally made to contracting agencies based on a percentage of the total Table A for the individual contractor. The allocations are updated periodically, driven by the hydrology and DWR’s ability to deliver SWP water to contracting agencies. The quantity of water available to United is reflected in Column 2 of Exhibit A and will vary from year to year depending on the percentage allocated by DWR in Column 1. This is exclusive of any Health and Safety allocations made pursuant to Article 18 of the VCWPD contract with DWR.
- d. The definitive agreement will include Casitas’ Table A and Article 21 as well as the ability for United to convey/store these supplies under Casitas’ rights within the State Water Project.

4. Pricing of Transferred Water

- a. United will pay Casitas the per acre foot price as shown in Column 3 of Exhibit A, corresponding to the final allocation percentage for the year as determined by DWR.
- b. United will pay Casitas no later than July 1 of each calendar year it receives Casitas’ final Table A allocation amount.
- c. Casitas will send an invoice no later than April 30 of each calendar year United receives Casitas’ final Table A water allocation amount.

- d. United will pay all SWP Variable charges for the Casitas Table A or Article 21 water delivered to its service area or to storage.

5. Resale of Transferred Casitas SWP Table A or Article 21

- a. United shall not sell or transfer water supplies that are transferred by Casitas.

General Terms and Approvals:

- a. Upon execution of this Term Sheet, related to the Program, Casitas and United shall (1) initiate preparation of any CEQA documents for environmental review and (2) prepare a definitive agreement intended to be finalized and executed by their respective Boards, along with any required CEQA compliance.
- b. Neither party will be bound by this term sheet until the definitive agreement is approved and executed by both parties.
- c. Casitas and United shall each be responsible for their own review and processing required agreements, environmental documents, and other transaction costs.

Terms acknowledged by:

Casitas Municipal Water District:

United Water Conservation District:

Michael Flood, General Manager

Mauricio Guardado, General Manager

Exhibit A

DRAFT – SUBJECT TO CHANGE AND NEGOTIATION

Exhibit A			
Casitas-United Water Deal Pricing Schedule			
Allocation Volume in AF Price Per AF Total Paid to Casitas			
100%	5000	\$275	\$1,375,000
95%	4750	\$275	\$1,306,250
90%	4500	\$275	\$1,237,500
85%	4250	\$275	\$1,168,750
80%	4000	\$300	\$1,200,000
75%	3750	\$325	\$1,218,750
70%	3500	\$350	\$1,225,000
65%	3250	\$375	\$1,218,750
60%	3000	\$400	\$1,200,000
55%	2750	\$425	\$1,168,750
50%	2500	\$450	\$1,125,000
45%	2250	\$475	\$1,068,750
40%	2000	\$500	\$1,000,000
35%	1750	\$525	\$918,750
30%	1500	\$550	\$825,000
25%	1250	\$575	\$718,750
20%	1000	\$600	\$600,000
15%	750	\$700	\$525,000
10%	500	\$700	\$350,000
5%	250	\$700	\$175,000

CASITAS MUNICIPAL WATER DISTRICT
Board of Directors Memo

DATE: July 7, 2022

TO: Board of Directors

FROM: Michael Flood, General Manager

SUBJECT: Approval of an application from Granite Construction Inc. for a temporary water service for the purposes of a concrete batch plant water supply for the State of California's Highway 101 improvement project.

RECOMMENDATION:

Approve the application.

BACKGROUND:

In December 2021, the Board approved an application for temporary water service for the purpose of grading/dust control connected to Granite Construction's repaving project on Highway 101 in the vicinity of Rincon Beach.

Staff recently received a second application from Granite Construction for a temporary direct connection to Casitas MWD's potable water system for the purpose of a concrete batch plant water supply for the same project.

DISCUSSION:

Granite Construction has been contracted by the State of California to replace pavement on a three-mile section of Highway 101 in the Rincon Beach area.

This project involves both southbound and northbound lanes and includes portions of off-ramp/on-ramp paving.

Granite expects to operate the plant during the months of July/August 2022 and again in the spring of 2023.

Total water demand is expected to be approximately 11-12 AF and Granite has applied for a term of approximately 12 months (August 2023).

Granite Construction staff has been advised that Casitas may discontinue permission for the use of District supplies for construction purposes at any time.

Given the nature and current status of the State's Highway 101 project, staff recommends the approval of this application.

Existing Account #- 91-91273-00



APPLICATION AND AGREEMENT FOR TEMPORARY WATER SERVICE

The undersigned applicant hereby applies for temporary water service and agrees to pay for such service and abide by the "Rates and Regulations for Water Service" of Casitas Municipal Water District as such Rates and Regulations are established and/or revised from time to time. **Deposit funds will be applied and withheld for any damages to District facilities for which the customer is liable in accordance with the Rates and Regulations.**

BILLING INFORMATION

Company Name: Granite Construction Contact Person: Carlos Ruvalcaba
Billing Address: 213 Columbia Way City, State Zip: Lancaster, CA 93535-5335
Telephone No.: 661-860-0746 Email: juan.ruvalcaba@gcinc.com

SERVICE INFORMATION

Desired Date of Service: July 1st, 2022 Today's Date: June 27th, 2022
Location of Service: Nearest Address: 5674 Pacific Coast HWY, Ventura CA 93001
Estimated Duration of Service: August 30, 2023
Purpose: Irrigation Construction Other: _____
Meter Size: 2½ inch Capacity: 300 gpm maximum
Pipeline Name: 6" Turn-out , Lower Ricon Main Station No.: STA 15+05

APPLICABLE FEES AND CHARGES (EFFECTIVE 10/1/2018)

Monthly Charge	\$150.00	Installation Fee	\$100.00
Relocate Meter	\$100.00	Deposit	\$500.00
Volumetric Rate	\$4.00/HCF*	Total Received with Application	\$600.00

The undersigned acknowledges receipt of a copy of this Application for Temporary Water Service and excerpts from Casitas' "Rates and Regulations for Water Service" dealing with Temporary Water Service and that undersigned is: 1) the Applicant for Temporary Water Service or 2) the Agent of and authorized by the Applicant to execute this Application for Temporary Water Service.

X 

Signature of Applicant or Authorized Agent of Applicant

Received by Casitas: Date: _____ By: _____
Engineering Manager

Approved by Casitas: Date: _____ By: _____
Operations Representative

Date: _____ By: _____
General Manager

Account No.: _____ S/O No. _____

*HCF - hundred cubic feet

6. TEMPORARY WATER SERVICE. Application for temporary water service shall be made in writing on a form provided by Casitas. Temporary service is intended primarily for construction and sanitary sewer flushing purposes. Provision of temporary water service shall not be considered mandatory, but shall be made at the sole discretion of Casitas. Temporary service will not be provided in those instances where Casitas determines that a permanent service would be more appropriate. Such determination by Casitas will be based in part upon the ultimate classification of the service to the applicant. Temporary water service, including temporary irrigation service, may be provided for a maximum period of six months. Periods of time in excess of six months may be approved by the Board of Directors. Casitas may remove such service at any time for any reason. Temporary irrigation service shall comply with all the applicable portions of Section 9, Water Rates, and Section 15, “Water Supply and Interruption of Delivery.”

6.1 INSTALLATION FEE. A meter installation fee of \$100.00 shall be paid by the applicant at the time temporary water service is requested; provided, that where temporary water service is desired from an outlet other than a fire hydrant and/or special piping or other fittings are required for the connection, the installation and relocation fees shall be increased to cover the actual cost of installation. No charge shall be made to the applicant for the cost of the meter. Credit for any salvageable materials used in the installation shall be in accordance with established Casitas policy and procedure.

6.2 GUARANTEE DEPOSIT. The applicant shall be required to deposit the sum of \$500.00 as a guarantee of payment of charges for temporary water service and as a guarantee of payment for any damage to Casitas property for which the customer is liable. If the customer is a water agency, or if the customer has established good credit to the satisfaction of Casitas as stated in Subsection 4.7.1, DEPOSITS, the \$500.00 deposit may be waived by Casitas’ Hearing Officer.

6.3 RELOCATION FEE. If a temporary water service customer requires service consecutively at two or more points in Casitas’ system, a relocation fee of \$100.00 shall be paid by the customer for each such change of location, the cost of which shall be accrued or paid at the time of billing. Relocations will be made by Casitas upon 24 hours’ notice, excluding Saturdays, Sundays and holidays, by the customer.

6.4 REIMBURSABLE CASITAS FACILITIES. Temporary water or temporary irrigation service shall not be provided to property that is liable for repayment to Casitas of costs associated with financing and construction of distribution facilities to serve said property.

6.5 WATER SERVICE TO NEW SUBDIVISION. Prior to receiving any water to a new subdivision, the developer must enter into an agreement to construct additions to the Casitas distribution system. During construction, the developer may receive water from a temporary meter connected to a fire hydrant, or other approved outlet in accordance with Section 6, “Temporary Water,” herein, and will be charged the rates called for in subsection 6.6, “Water Rates For Temporary Service.” Prior to acceptance of the new distribution facilities by Casitas, developer will take out an application, or have an application taken out, for each service in the subdivision. Deposits will be in accordance with subsection 4.7.1, “Deposits,” “Service Facility Fees” will be in accordance with subsection 4.8, “Water Rates,” in accordance with subsection 9.3, and “Service Charges” in accordance with subsection 9.4.

6.6 WATER RATES FOR TEMPORARY SERVICE. The water rates and service charges for temporary service, except for temporary irrigation service shall be in accordance with Subsections 9.3.1, “Rate Schedule”, and 9.4.2, “Service Charges”, respectively.

6.7 DISREGARD OF “RATES AND REGULATIONS FOR WATER SERVICE.” Willful disregard of these “Rates and Regulations for Water Service” or special arrangements made for temporary service shall result in immediate discontinuance of such service and forfeiture of the deposit.

CASITAS MUNICIPAL WATER DISTRICT
Board of Directors Memo

DATE: July 7, 2022

TO: Board of Directors

FROM: Michael Flood, General Manager

SUBJECT: Approval of an application from Security Paving Company, Inc. for a temporary water service for the purposes of a construction water supply for the State of California's Highway 33/San Antonio Bridge improvement project.

RECOMMENDATION:

Approve the application.

BACKGROUND:

The State of California has contracted with Security Paving Company, Inc. for the Highway 33/San Antonio Bridge improvement project.

Security Paving applied to the District for a temporary water supply for construction purposes related to the project.

DISCUSSION:

Security Paving has been contracted by the State of California for improvements to the Highway 33 bridge at San Antonio Creek.

Security Paving expects to need this supply from July 2022 through December 2023 (18 months) and total water demand is expected to be approximately 1.5 to 2 AF.

Security Paving staff has been advised that Casitas may discontinue the permission for the use of District supplies for construction purposes at any time.

Given the nature and current status of the State's Highway 33/San Antonio Bridge improvement project, staff recommends the approval of this application.



APPLICATION AND AGREEMENT FOR TEMPORARY WATER SERVICE

The undersigned applicant hereby applies for temporary water service and agrees to pay for such service and abide by the "Rates and Regulations for Water Service" of Casitas Municipal Water District as such Rates and Regulations are established and/or revised from time to time. Deposit funds will be applied and withheld for any damages to District facilities for which the customer is liable in accordance with the Rates and Regulations.

BILLING INFORMATION

Company Name: Security Paving Company, Inc Contact Person: Karla Moralas
Billing Address: 3075 Townsgate Rd. #200 City, State Zip: Westlake Village, CA 91361
Telephone No.: 818.362.9200 Email: kmoralas@securitypaving.com

If related to a District Capital Project, Account No. _____ Project No. _____

SERVICE INFORMATION

Desired Date of Service: 7/11/22 Today's Date: 6/30/22

Location of Service: Rancho Arnaz Pressure Station

Estimated Duration of Service: 18 months

Purpose: Irrigation Construction Other: _____

Meter Size: 2½ inch Capacity: 300 gpm maximum

Pipeline Name: _____ Station No.: _____

APPLICABLE FEES AND CHARGES (EFFECTIVE 10/1/2018)

Monthly Charge	\$150.00	Installation Fee	\$100.00
Relocate Meter	\$100.00	Deposit	<u>\$500.00</u>
Volumetric Rate	\$4.00/HCF*	Total Received with Application	\$600.00

The undersigned acknowledges receipt of a copy of this Application for Temporary Water Service and excerpts from Casitas' "Rates and Regulations for Water Service" dealing with Temporary Water Service and that undersigned is: 1) the Applicant for Temporary Water Service or 2) the Agent of and authorized by the Applicant to execute this Application for Temporary Water Service. The undersigned is responsible for providing a meter cap and capping the meter when not in use. Casitas is not responsible for water theft; undersigned is responsible for all water use registered on the meter.

Signature of Applicant or Authorized Agent of Applicant

[Signature]
Approved by Casitas:

[Signature]
Engineering Manager

Operations Representative

General Manager

Account No.: _____ S/O No. _____

*HCF - hundred cubic feet



July 8, 2022

Board of Directors
Casitas Municipal Water District
1055 Ventura Avenue
Oak View, CA 93022

Re: Claims of Jennifer and Antar Ron

Dear Board Members:

The District received two claims from Jennifer and Antar Ron on March 24, 2022. Copies of these claims are attached hereto.

Both claims are related to a tree falling on their trailer while at the Lake Casitas Recreational Area.

The first claim is for \$250 which is the insurance deductible on the Ron's insurance policy. The Ron's submitted their claim to their insurance carrier, and the insurance covered the damage and the Ron's are now seeking the \$250 deductible.

The second claim is for \$513.59, which constitutes a motel bill for the time that the Ron's trailer was being repaired.

It is our recommendation that the District accept the first claim of \$250 and pay that to the Ron's with their execution of a Release Agreement. We further recommend that the second claim for the motel bill be denied.

KENDALL A. VANCONAS* | ROBERT N. KWONG | SUSAN L. MCCARTHY

OF COUNSEL GARY D. ARNOLD | JOHN M. MATHEWS | DENNIS LAROCHELLE | MARK A. ZIRBEL** | DEAN W. HAZARD

300 ESPLANADE DR. SUITE 2100 | OXNARD, CA 93036
T 805.988.9886 F 805.988.1937 WWW.ATOZLAW.COM

*Certified Specialist, Estate Planning, Trust & Probate Law
State Bar of California, Board of Legal Specialization

**Retired

July 8, 2022
Page 2

We'll be happy to answer any questions at the board meeting.

Very truly yours,

ARNOLD LAROCHELLE MATHEWS
VANCONAS & ZIRBEL LLP

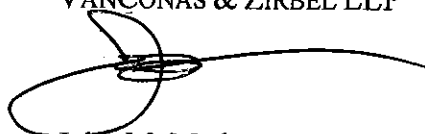
A handwritten signature in black ink, consisting of a large, stylized loop followed by a horizontal line that tapers to the right.

John M. Mathews

JMM:MG

Jennifer (805) 294-0392
Antar (805) 607-~~3480~~ 3480

MAR 24 2022

CASITAS MUNICIPAL WATER DISTRICT
CLAIM FORM

Claimant must show:

Today's Date: 3/23/22

Name Jennifer & Antar Ron

Address 4744 Telephone rd #3253

PO Box or address to which claimant wants notices to be sent
Ventura CA 93003

Date of circumstance or occurrence

8/6/21

Place of circumstance or occurrence

Tree fell on travel trailer in section B

Other circumstances which gave rise to the claim

Insurance paid for damages
just seeking amount of
deductable of \$250

General description of indebtedness, obligation, injury, damage or loss incurred so far as it may be known at the time of presentation of the claim:

We live in our trailer and
we had to wait for the
repair shop to collect all the
parts. We were displaced
for 7 days due to repairs

Name or names of public employees causing the injury, damage, or loss if known.

The amount claimed if it totals less than ten thousand dollars (\$10,000) as of the date of presentation of the claim, including the estimated amount of any prospective injury, damage, or loss insofar as it may be known at the time of the claim together with the basis of computation of the amount claims. If the amount claimed exceeds ten thousand dollars (\$10,000), no dollar amount shall be included in the claim; however, it shall indicate whether jurisdiction over the claim would rest in municipal or superior court.

\$ 250 deductible

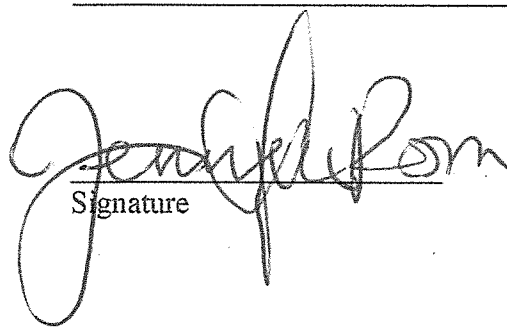
 3/23/20
Signature Date

C & S RV, Inc.

SERVICE INVOICE

1254 Mercantile St, Oxnard US-CA 93030
 Phone: (805)982-9900 Fax: (805)240-9871

PAGE	ORDER #	INVOICE #
2 of 3	10112204	10112624

CUSTOMER COPY



7832 Ron, Antar

Date		Promised		Terms		Model	
08/11/2021				Cash		HIDEOUT	
Home Phone		PO Number		V.I. Number			
(805)607-3480				4YDT21F29HN200084			
Work Phone		E-mail Address		Prod Date		Ref No	
FAX		Service Advisor		Odometer		License	
		Candy		0		1MG4295	

Customer Name Address	
Ron, Antar	
4744 Telephone Rd. 3253	
Ventura, CA 93003	
United States	

Qty	SKU#	MFG	Part Number	Description	Unit Price	Total
1.00	133081	MIS	xxxx	Diflex 2 Roof Membrane 9.6x30 Tan	\$695.00	\$695.00
1.00	140661	DICOR	401CKT	ROOF INSTALL KIT	\$313.00	\$313.00
1.00	141410	LCI	V000287292	AWNING, ROLLER/FABRIC BLK W/LED 14FT	\$738.65	\$738.65
1.00	141411	LCI	V000406455	ARMS, SET BLK POWER	\$913.65	\$913.65
1.00	141402	HOL	520164	METAL, 9"X9, MESA BEIGE	\$67.60	\$67.60
1.00	141403	HOL	477825	METAL, 36"X9, MESA BEIGE	\$261.00	\$261.00
1.00	141404	HOL	477824	METAL, 18"X9, MESA BEIGE	\$71.50	\$71.50
1.00	141405	HOL	123227	NON INSERT ROOF TRIM, BLK ALUM	\$39.90	\$39.90
1.00	141406	HOL	410501	ALUMINUM TRIM VERTICAL BLK	\$45.50	\$45.50
1.00	141407	HOL	483706	DECAL, REAR	\$198.85	\$198.85
1.00	141408	HOL	483707	DECAL, REAR	\$15.50	\$15.50
1.00	141409	HOL	483676	DECAL, REAR	\$115.05	\$115.05
6.00	118057	HD	166006	Luan Wood Skin	\$41.00	\$246.00
1.00	133081	MIS	xxxx	Misc Shop Supplies	\$58.00	\$58.00
1.00	133081	MIS	xxxx	A/c Roof Gasket	\$29.99	\$29.99
1.00	139485	MIS	SHIPPING	SHIPPING	\$0.00	\$0.00
Total Parts						\$3,809.19

Hours	Service Code	Service Description	Rate	Total
0.00	01	EST BODY REPAIR <i>Technician:</i>	\$130.00	\$0.00
1.80	02	R&R DS REAR WINDOW <i>Technician:</i>	\$130.00	\$234.00

Special Notes

The Parts and Accessories sold and installed by this Repair Shop and the Service connected with the installation and adjustments of the Parts and Accessories sold and installed by this Repair Shop, are Guaranteed to be free from defects in material and workmanship under normal service. Parts installed are not warranted beyond warranties given by the respective manufactures. No other warranties are made except as listed on this invoice. 90 Days Warranty on Labor. I have inspected all services performed and parts installed and accept that all was done to my complete satisfaction. We are not responsible for loss of personal items or valuables left in vehicles from fire or theft while in our possession for repair or storage.

Parts	Continued on Next Page	
Labor		
Sublet		
Misc		
Sub Total		
9.250% Tax		
Discount		
Handling		
Total Sale		
Payment History		
Check #	Date	Amount

Customer Signature: _____ Date: _____

C & S RV, Inc.

SERVICE INVOICE

1254 Mercantile St, Oxnard US-CA 93030
 Phone: (805)982-9900 Fax: (805)240-9871

PAGE	ORDER #	INVOICE #
3 of 3	10112204	10112624

CUSTOMER COPY



7832 Ron, Antar

Customer Name Address
 Ron, Antar
 4744 Telephone Rd. 3253
 Ventura, CA 93003
 United States

Date	Promised	Terms	Model
08/11/2021		Cash	HIDEOUT
Home Phone	PG Number	V.I. Number	
(805)607-3480		4YDT21F29HN200084	
Work Phone	E-mail Address	Prod Date	Ref No
FAX	Service Advisor	Odometer	License
	Candy	0	1MG4295

Hours	Service Code	Service Description	Rate	Total
1.80	03	R&R DS REAR WALL EXTR <i>Technician:</i>	\$130.00	\$234.00
1.00	04	R&I TOP REAR ROOF LINE MOLDING <i>Technician:</i>	\$130.00	\$130.00
1.50	05	R&I PS REAR WALL EXTR <i>Technician:</i>	\$130.00	\$195.00
1.50	06	R&R REAR WALL BOTTOM PANEL <i>Technician:</i>	\$130.00	\$195.00
1.50	07	R&R REAR WALL 2ND PANEL <i>Technician:</i>	\$130.00	\$195.00
1.50	08	R&R REAR WALL 3RD PANEL <i>Technician:</i>	\$130.00	\$195.00
1.50	09	R&R REAR WALL TOP PANEL <i>Technician:</i>	\$130.00	\$195.00

Special Notes

The Parts and Accessories sold and installed by this Repair Shop and the Service connected with the installation and adjustments of the Parts and Accessoriessold and installed by this Repair Shop, are Guaranteed to be free from defects in material and workmanship under normal service. Parts installed are not warranted beyond warranties given by the respective manufactures. No other warranties are made except as listed on this invoice. 90 Days Warranty on Labor. I have inspected all services preformed and parts installed and accept that all was done to my complete satisfaction. We are not responsible for loss of personal items or valuables left in vehicles from fire or theft while in our possession for repair or storage.

Parts :	\$3,809.19	
Labor :	\$5,759.00	
Sublet :	\$0.00	
Misc :	\$0.00	
Sub Total :	\$9,568.19	
9.250% Tax :	\$352.35	
Discount :	\$0.00	
Handling :	\$0.00	
Total Sale :	\$9,920.54	
Payment History		
Check #	Date	Amount
0006503009	02/18/2022	\$9,670.54
Cash	02/18/2022	\$130.00
Cash	02/18/2022	\$120.00
Payments :		\$9,920.54
Balance Due :		\$0.00

Customer Signature: _____ Date: _____

C & S RV, Inc.

SERVICE INVOICE

1254 Mercantile St, Oxnard US-CA 93030
 Phone: (805)982-9900 Fax: (805)240-9871

PAGE	ORDER #	INVOICE #
1 of 3	10112204	10112624

CUSTOMER COPY



7832 Ron, Antar

Date	Promised	Terms	Model
08/11/2021		Cash	HIDEOUT
Home Phone	PO Number	V.I. Number	
(805)607-3480		4YDT21F29HN200084	
Work Phone	E-mail Address	Prod Date	Ref No
FAX	Service Advisor	Odometer	License
	Candy	0	1MG4295

Customer Name	Address
Ron, Antar	4744 Telephone Rd. 3253 Ventura, CA 93003 United States

Hours	Service Code	Service Description	Rate	Total
1.30	10	R&I REAR MARKER LIGHTS <i>Technician:</i>	\$130.00	\$169.00
1.50	11	R&R PATIO AWNING <i>Technician:</i>	\$130.00	\$195.00
1.50	12	R&I ONE VENT W MAX AIR COVER <i>Technician:</i>	\$130.00	\$195.00
1.50	13	R&I ROOF AC UNIT <i>Technician:</i>	\$130.00	\$195.00
1.00	14	R&I REFER VENT <i>Technician:</i>	\$130.00	\$130.00
1.50	15	R&I SKYLIGHT <i>Technician:</i>	\$130.00	\$195.00
0.40	16	R&I SEWER VENTS <i>Technician:</i>	\$130.00	\$52.00
1.00	17	R&I ANTENNA <i>Technician:</i>	\$130.00	\$130.00

Special Notes

The Parts and Accessories sold and installed by this Repair Shop and the Service connected with the installation and adjustments of the Parts and Accessoriessold and installed by this Repair Shop, are Guaranteed to be free from defects in material and workmanship under normal service. Parts installed are not warranted beyond warranties given by the respective manufactures. No other warranties are made except as listed on this invoice. 90 Days Warranty on Labor. I have inspected all services preformed and parts installed and accept that all was done to my complete satisfaction. We are not responsible for loss of personal items or valuables left in vehicles from fire or theft while in our possession for repair or storage.

Parts	Continued on Next Page	
Labor		
Sublet		
Misc		
Sub Total :		
9.250% Tax		
Discount		
Handling		
Total Sale :		
Payment History		
Check #	Date	Amount

Customer Signature: _____ Date: _____

C & S RV, Inc.

1254 Mercantile St, Oxnard US-CA 93030
 Phone: (805)982-9900 Fax: (805)240-9871

SERVICE INVOICE

PAGE	ORDER #	INVOICE #
2 of 3	10112204	10112624

CUSTOMER COPY



7832 Ron, Antar

Date		Promised		Terms		Model	
08/11/2021				Cash		HIDEOUT	
Home Phone		PO Number		V.I Number			
(805)607-3480				4YDT21F29HN200084			
Work Phone		E-mail Address		Prod Date		Ref No	
FAX		Service Advisor		Odometer		License	
		Candy		0		1MG4295	

Customer Name Address	
Ron, Antar	
4744 Telephone Rd. 3253	
Ventura, CA 93003	
United States	

Hours	Service Code	Service Description	Rate	Total
3.00	18	R&I SIDE ROOF MOLDINGS <i>Technician:</i>	\$130.00	\$390.00
18.00	19	R&R RUBBER ROOF MEMBRANE <i>Technician:</i>	\$130.00	\$2,340.00
1.00	20	RESEAL REPAIRED AREA <i>Technician:</i>	\$130.00	\$130.00
0.50	21	R&R REAR LUGGAGE RACK <i>Technician:</i>	\$130.00	\$65.00
Total Labor				\$5,759.00

Special Notes

The Parts and Accessories sold and installed by this Repair Shop and the Service connected with the installation and adjustments of the Parts and Accessoriessold and installed by this Repair Shop, are Guaranteed to be free from defects in material and workmanship under normal service. Parts installed are not warranted beyond warranties given by the respective manufactures. No other warranties are made except as listed on this invoice. 90 Days Warranty on Labor.I have inspected all services preformed and parts installed and accept that all was done to my complete satisfaction. We are not responsible for loss of personal items or valuables left in vehicles from fire or theft while in our possession for repair or storage.

Parts :	Continued on Next Page	
Labor :		
Sublet :		
Misc :		
Sub Total :		
9.250% Tax :		
Discount :		
Handling :		
Total Sale :		
Payment History		
Check #	Date	Amount

Customer Signature: _____ Date: _____

Jennifer 805) ~~800~~ 294-0392

Antar 805) 607-3480

MAR 24 2022

CASITAS MUNICIPAL WATER DISTRICT
CLAIM FORM

Claimant must show:

Today's Date: 3/23/22

Name Jennifer, Antar Rom

Address 4744 Telephone rd #3253

PO Box or address to which claimant wants notices to be sent
Ventura CA 93003

Date of circumstance or occurrence

8/6/21

Place of circumstance or occurrence

Lake Casitas Camp Ground

Other circumstances which gave rise to the claim

Tree fell on our travel trailer causing extensive damages. Insurance paid for damages but we are seeking the amount paid to stay in a motel while

General description of indebtedness, obligation, injury, damage or loss incurred so far as it may be known at the time of presentation of the claim:

trailer was repaired. the repair shop only took 7 days. the motel bill is attached. We reside in our RV full time.

Name or names of public employees causing the injury, damage, or loss if known.

The amount claimed if it totals less than ten thousand dollars (\$10,000) as of the date of presentation of the claim, including the estimated amount of any prospective injury, damage, or loss insofar as it may be known at the time of the claim together with the basis of computation of the amount claims. If the amount claimed exceeds ten thousand dollars (\$10,000), no dollar amount shall be included in the claim; however, it shall indicate whether jurisdiction over the claim would rest in municipal or superior court.

\$ 513.59

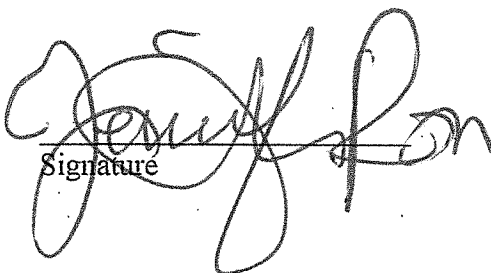
 3/23/02
Signature Date

Good Nite Inn Camarillo



1100 Ventura Boulevard, Camarillo (CA), United States

[Directions](#)

Check in
Friday, February 11, 2022
(after 15:00)

Check out
Friday, February 18, 2022
(before 11:00)

You can also easily find out about property policies and amenities in [My bookings](#)

For any questions related to the property, please contact them directly.

Tel: 0000000000000000

Important Information

Guests must register their vehicles during check-in and parking is limited to one vehicle per room. No oversize trucks, trailers, or recreational vehicles are permitted.

The pool is temporarily closed due to Covid-19 restrictions.

Pool temporarily will be closed until May 31, 2021, and there will be limited capacity after reopen(1 June ,2021)

Booking Information

Reservation	1 room, 7 nights
Room type	1 Queen Bed Deluxe
Promotion	Limited Time Offer. Super Hot Deal
Lead guest	Jennifer GibsonRon
Occupancy	2 adults
Benefits	Wi-Fi, Parking, Free WiFi

Special request Smoke, I'd like a large bed

All special requests are subject to availability upon arrival.

Your booking is paid and confirmed

1 room(s) x 7 night(s) USD 513.59

Total Charge **USD 513.59**

Included : Taxes and fees USD 59.08



Agoda price guarantee

Paid with credit card

XXXX-XXXX-XXXX-5166

Cancellation Policy

Partially Refundable

From 11 Feb 12:00 AM Booked

Important Information

Any cancellation received within 1 day prior to the arrival date will incur the first night's charge.

Failure to arrive at your hotel or property will be treated as a No-Show and will incur the first night's charge (Hotel policy).

My bookings

Using our convenient self-service, you can sign into your account any time to re-send confirmations, get a receipt, make requests, cancel your booking, change dates or amend guest name.



Share booking
confirmation

Resend your booking confirmation to yourself or others.



Send a receipt

Get a receipt sent to you for business use.

Special requests

Ask the property to add extra beds, breakfast, or amenities.



Cancel booking

Cancel your booking online easily.



Change dates

Amend your booking dates.



Manage guests

Amend the lead guest's name.

Need more information or support?

Keep your booking reference number **466019006** handy and within reach. You'll need it if you would like to contact our customer support.

Quickly find out how you can manage your booking online in our content rich FAQ library.

[Browse our FAQ for quick answers](#)

Important Notes

- Important notice: to protect your personal data and payment information, never disclose your personal data or payment information or transfer funds to any person calling or messaging you from unofficial communication channels outside of Agoda's platform. If you have received such communications, please report any suspicious or fraudulent activity by contacting our customer support and always check with us if you are unsure before responding to external or suspicious communications (calls, emails, text messages, etc.)
- **IMPORTANT:** At check-in, you must present a valid photo ID with your address confirming the same name as the lead guest on the booking. For bookings paid with a credit card, you may also need to present the card used to make the payment. Failure to do so may result in the hotel requesting additional payment or your reservation not being honored.

- All rooms are guaranteed on the day of arrival. In the case of a no-show, your room(s) will be released and you will be subject to the terms and conditions of the Cancellation/No-Show Policy specified at the time you made the booking as well as noted in the Confirmation Email.
- The total price for this booking does not include mini-bar items, telephone usage, laundry service, etc. The property will bill you directly.
- In cases where Breakfast is included with the room rate, please note that certain properties may charge extra for children travelling with their parents. If applicable, the property will bill you directly. Upon arrival, if you have any questions, please verify with the property.

Make your next booking even easier with the Agoda app



Get even better deals and prices on rooms



Manage your booking from anywhere, any time



This is a post-only mailing. Please do not respond to this message.

--
H.W.H PROPERTY



Booking Confirmation

Please present either an electronic or paper copy of your booking confirmation upon check-in.

agoda	agoda	agoda	agoda	agoda	agoda	agoda	agoda	agoda	agoda	agoda	
Booking ID :	466019006			Number of Rooms :	1						
Booking Reference No :				Number of Extra Beds :	0						
Client :	Jennifer GibsonRon			Number of Adults :	2						
Member ID :	337530381			Number of Children :	0						
Country of Residence :	United States			Room Type :	1 Queen Bed Deluxe						
Property :	Good Nite Inn Camarillo			Promotion :	Limited Time Offer. Super Hot Deal						
Address :	1100 Ventura Boulevard, Camarillo, Camarillo (CA), United States, 93010			For Full Promotion details and conditions see confirmation email							
Property Contact Number :	+0000000000000000										

Cancellation Policy: Any cancellation received within 1 day prior to the arrival date will incur the first night's charge. Failure to arrive at your hotel or property will be treated as a No-Show and will incur the first night's charge (Hotel policy).

Benefits Included Wi-Fi, Parking, Free WiFi

Arrival : February 11, 2022 Departure : February 18, 2022

Booked And Payable By :

Agoda Company Pte, Ltd.
30 Cecil Street, Prudential Tower #19-08,
Singapore 049712

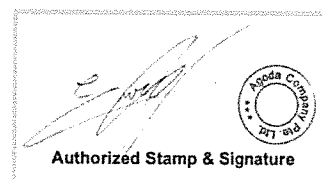

Remarks :

Included : Taxes and fees USD 59.08
Smoke, Large Bed

All special requests are subject to availability upon arrival

Call our Customer Service Center 24/7 :
Customer Support : +xx xxx xxxx
(Long distance charge may apply)

Notes

- **IMPORTANT:** At check-in, you must present a valid photo ID with your address confirming the same name as the lead guest on the booking. For bookings paid with a credit card, you may also need to present the card used to make the payment. Failure to do so may result in the hotel requesting additional payment or your reservation not being honored.
- All rooms are guaranteed on the day of arrival. In the case of a no-show, your room(s) will be released and you will be subject to the terms and conditions of the Cancellation/No-Show Policy specified at the time you made the booking as well as noted in the Confirmation Email.
- The total price for this booking does not include mini-bar items, telephone usage, laundry service, etc. The property will bill you directly.
- In cases where Breakfast is included with the room rate, please note that certain properties may charge extra for children travelling with their parents. If applicable, the property will bill you directly. Upon arrival, if you have any questions, please verify with the property.

CASITAS MUNICIPAL WATER DISTRICT

MINUTES

Finance Committee

(this meeting was held telephonically and in-person)

DATE: July 5, 2022
TO: Board of Directors
FROM: General Manager, Michael Flood
Re: Finance Committee Meeting of June 17, 2022 at 1000 hours.

RECOMMENDATION:

It is recommended that the Board of Directors receive and file this report.

BACKGROUND AND OVERVIEW:

1. **Roll Call.**

Director Neil Cole
Director Richard Hajas
General Manager, Michael Flood
Assistant General Manager, Kelley Dyer
Chief Financial Officer, Janyne Brown

2. **Public Comments.**

None

3. **Board/Management comments.**

None

4. **Bill Relief Program for Conservation Penalty Appeals and Leak Relief**

AGM Dyer covered the contents of the Committee Memo with the Committee.

The Committee directed that the program be forwarded to the Board of Directors for consideration.

5. **Casitas MWD 20-Year Capital Replacement Program and Development**

GM Flood covered the contents of the Committee Memo with the Committee.

6. **Proposition 4 – Establishment of Appropriations Limit for 2022-2023**

CFO Brown discussed the item with the Committee.

The Committee directed that this item be forwarded to the Board of Directors for consideration.

7. **Review of Financial Statements for April 2022**

CFO Brown reviewed the Financial Statements with the Committee.

8. **Review of the Consumption Report for April 2022.**

GM Flood covered the report with the Committee.

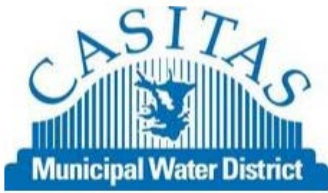

Casitas Municipal Water District
State Water Project - Interconnect Project Costs
As of 6/30/2022

Project No:	Project Name:	Costs paid to date	Encumbered	Total Encumbered & Cost To Date
378	State Water Interconnect - Calleguas to Casitas	123,667.60	-	123,667.60
527	State Water Interconnect - Carpinteria to Casitas	1,121,887.17	2,260,984.72	3,382,871.89
606	State Water Interconnect - Ventura to Casitas	249,242.35	-	<u>249,242.35</u>
Project(s) Cost To Date:				<u><u>3,755,781.84</u></u>



**Casitas Municipal Water District
CFD 2013-1 Improvement Fund - Series B**

	Bonds Proceeds Received (1)	Interest Earned (2)	Expense (3)	Balance Series B (1)+(2)+(3)
2017 Subtotal	42,658,223.98	24,046.16	(36,886,093.06)	
TOTAL	42,658,223.98	24,046.16	(36,886,093.06)	5,796,177.08
2018 Subtotal	-	77,279.16	-	
TOTAL	42,658,223.98	101,325.32	(36,886,093.06)	5,873,456.24
2019 Subtotal	-	102,268.61	(1,486,814.43)	
TOTAL	42,658,223.98	203,593.93	(38,372,907.49)	4,488,910.42
2020 Subtotal	-	15,749.88	(4,404,999.69)	
TOTAL	42,658,223.98	219,343.81	(42,777,907.18)	99,660.61
2021 Subtotal	-	2.16	(99,662.60)	
TOTAL	42,658,223.98	219,345.97	(42,877,569.78)	0.17
2022 Subtotal	-	-	-	
TOTAL	42,658,223.98	219,345.97	(42,877,569.78)	0.17

**Casitas Municipal Water District
CFD 2013-1 Improvement Fund - Series C**

	Bonds Proceeds Received (1)	Interest Earned (2)	Expense (3)	Balance Series C (1)+(2)+(3)
2019 Subtotal	13,570,000.00	12,284.84	-	
TOTAL	13,570,000.00	12,284.84	-	13,582,285
2020 Subtotal	-	48,026.34	(1,362,971.53)	
TOTAL	13,570,000.00	60,311.18	(1,362,971.53)	12,267,339.65
2021 January		62.37		
February		62.37		
March		57.01		
April		62.37		
May		60.36	(537,876)	Project Reimbursement (Apr exp)
June		60.16	(662,386)	Project Reimbursement (May exp)
July		54.67	(1,150,111)	Project Reimbursement (June exp)
August		51.74	(719,027.97)	Project Reimbursement (July exp)
September		47.83		
October		45.26	(1,233,220.94)	Project Reimbursement (Aug & Sept exp)
November		42.26		
December		65.43	(510,100.59)	Project Reimbursement (Oct & Nov exp)
2021 Subtotal	-	671.83	(4,812,722.59)	
TOTAL	13,570,000.00	60,983.01	(6,175,694.12)	7,455,288.89
2022 January		38.40		
February		37.90		
March		34.68	(110,796.25)	Project Reimbursement (Dec 2021-Feb 2022 exp)
April		37.65	(105,962.81)	Project Reimbursement (Mar 2022)
May		35.82		
June		1,782.24	(420,831.29)	Project Reimbursement (Apr & May 2022)
July				
August				
September				
October				
November				
December				
2022 Subtotal	-	1,966.69	(637,590.35)	
TOTAL	13,570,000.00	62,949.70	(6,813,284.47)	6,819,665.23

Summary of Expenses

CFD 2013-1 Improvement Fund - Series B&C

Purchase of Ojai System	34,481,628.00
Extension Contract	366,371.55
Meter Cost	2,038,093.51
Received Project reimbursements:	12,804,761.19
	49,690,854.25

Total funds remaining for improvement Series B:	0.17
Total funds remaining for improvement Series C:	6,819,665.23
Total Funds Remaining	6,819,665.40
Received Project reimbursements:	12,804,761.19
Projects Cost YTD:	13,451,535.07
Projects Pending Reimbursement:	646,773.88
Total Funds Remaining less pending Reimbursement:	6,172,891.52

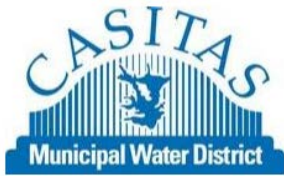

Casitas Municipal Water District
CFD 2013 - 1 Projects to be reimbursed to CMWD To Date
As of 6/30/2022

Project No:	Project Name:	Costs
400	Ojai System Masterplan	375,336.49
420	Sunset Place Pipeline Replacement	785,031.23
421	Cuyama, Palomar and El Paseo Roads Pipeline Replacement	2,170,276.95
422	South San Antonio Street and Crestview Drive Pipeline	89,258.17
423	West and East Ojai Avenue Pipeline Replacement	622,762.72
424	Running Ridge Zone Hydraulic Improvement	445,850.04
425	Well Rehabilitation Replacement	1,524,839.27
426	Valve & Appurtenance Replacement	1,136,796.97
427	Fairview Pipeline Replacement	167,086.68
428	Mutual Wellfield Pipeline	167,621.61
429	Grand Ave Pipeline	56,650.86
430	Signal Booster Zone Hydraulic Improvements	165,699.18
431	Emily Street Pipeline Replacement	1,055,084.68
432	Casitas-Ojai System Interties	78,158.82
522	Ojai Arc Flash Study	119,839.00
611	Mutual Replacement Well	438,973.36
411	Replace San Antonio #3 Well	29,759.77
506	Ojai SCADA UPS Units	11,447.67
509	Hypochlorite Tanks OS	24,186.95
511	Ojai Wellfield Cla-Vals	4,273.91
512	Well Monitoring Upgrades 07/2018	1,520.76
514	Ojai Wellfield Mag Meters 07/2018	18,876.70
433	Ojai 12" pipeline replac	2,015,232.30
434	Heidelberger PP Ret. Wal	108,046.78
435	Plesant Ave/Daily Rd Pip	62,644.70
436	OWS Tank/Valt Fall Impro	23,274.45
437	Wellvield VFDs	436,490.04
438	Lion St PL/ Fairview Conn	762,333.09
646	OWS Arbolada Tank	64,981.56
673	Mutual Well #7	480,600.36
674	San Antonio Filter Upgrade	8,600.00
Project(s) Cost To Date:		<u>13,451,535.07</u>



**Casitas Municipal Water District
Adjudication Charge Summary Report**

	2020 July	2020 August	2020 September	2020 October	2020 November	2020 December	2021 January	2021 February	2021 March	2021 April	2021 May	2021 June	FY21 YTD
Revenue	(48,685)	(48,893)	(48,945)	(49,160)	(49,090)	(48,787)	(49,013)	(48,754)	(48,737)	(49,088)	(48,639)	(46,304)	(584,095)
Expenses													
Legal	-	26,378	15,228	-	29,451	4,917	4,625	14,288	1,344	32,955	15,958	23,411	168,555
Other Pro Fees	-	-	-	-	-	-	20,322	14,782	-	-	7,813	82,257	125,175
Bank Fees	-	-	-	-	130	-	-	-	-	-	-	-	130
Net Total	(48,685)	(22,515)	(33,717)	(49,160)	(19,509)	(43,870)	(24,066)	(19,684)	(47,393)	(16,133)	(24,868)	59,364	(290,234)
Cash Collected	948	2,630	44,674	48,421	47,746	50,454	48,260	46,160	52,298	46,680	49,070	46,673	484,014
Cash Disbursed	-	(26,378)	(15,228)	(0)	(29,573)	(4,917)	(24,955)	(29,070)	(1,344)	(32,955)	(23,771)	(63,445)	(251,637)
Accounts Payable	-	-	-	-	(8)	-	8	-	-	-	(0)	(42,224)	(42,224)
Accounts Receivable	47,737	46,263	4,271	738	1,344	(1,667)	754	2,594	(3,561)	2,408	(431)	(369)	100,081
Net Total	48,685	22,515	33,717	49,160	19,509	43,870	24,066	19,684	47,393	16,133	24,868	(59,364)	290,235

	2021 July	2021 August	2021 September	2021 October	2021 November	2021 December	2022 January	2022 February	2022 March	2022 April	2022 May	2022 June	9	YTD
Revenue	(48,514)	(48,430)	(48,489)	(48,520)	(48,464)	(48,355)	(48,545)	(48,400)	(48,345)	(48,018)	(48,499)			(1,116,664)
Expenses														
Legal	-	1,908	12,847	9,838	24,067	38,114	-	54,949	46,935	140,549	23,364	23,200		544,326
Other Pro Fees	-	10,122	5,718	13,835	22,554	27,345	45,786	20,995	14,643	32,509	3,525	26,169		348,375
Bank Fees	-	-	-	-	-	-	-	-	-	-	-	-		130
Net Total	(48,514)	(36,400)	(29,925)	(24,847)	(1,843)	17,104	(2,759)	27,545	13,233	125,040	(21,610)	49,379		(223,833)
Cash Collected	50,335	46,498	49,795	48,266	47,348	49,062	48,507	46,747	49,424	49,471	47,847	37,182		1,054,497
Cash Disbursed	(32,144)	(22,110)	(18,564)	(23,673)	(46,621)	(65,459)	(45,786)	(75,944)	(61,578)	(173,058)	(27,233)	(50,036)		(893,842)
Accounts Payable	32,144	10,079	-	-	-	(0)	(0)	-	-	0	(0)	0		0
Accounts Receivable	(1,821)	1,932	(1,306)	253.23	1,115	(707)	38	1,652	(1,079)	(1,453)	995	(36,525)		63,177
Net Total	48,514	36,400	29,925	24,847	1,843	(17,104)	2,759	(27,545)	(13,233)	(125,040)	21,610	(49,379)		223,833

Note: Data as of 6/30/2022	-	-	-	-	(0.00)	-	(0.00)	-	(0.00)	-	-	-		160,656
----------------------------	---	---	---	---	--------	---	--------	---	--------	---	---	---	--	---------



**Casitas Municipal Water District
Revenue & Expense Report
For the Month Ending, April 30th, 2022**

% of the Year Completed: 83.33%

	Current Budget (a)	Current Period Balance	Year to Date Balance (b) FY2022	Prior Year to Date Balance FY2021
Water Sales	8,492,083	574,316	7,992,938	7,605,925
Water Standby	5,075,845	462,777	4,730,661	4,200,891
Water Delinquency & Penalties	97,951	101,176	921,959	1,161,694
Water Other	15,218	100	14,400	13,925
Recreation- Operations	3,871,270	559,162	3,169,585	2,770,491
Recreation- Water Park	542,776	720	2,220	(75)
Miscellaneous Operational	446,849	25,522	360,930	318,441
Subtotal Operating Revenue (d)	18,541,992	1,723,773	17,192,692	16,071,291
Miscellaneous Non-Operational	732,162	1,348	59,572	838,941
Grants/ Reimbursements	1,425,000	8,046	433,380	-
Taxes & Assessments	6,275,639	2,604,312	6,532,446	6,260,273
Miscellaneous	-	-	-	-
Subtotal Non-Operating Revenue (e)	8,432,801	2,613,706	7,025,398	7,099,214
Total Revenue (d+e)	26,974,793	4,337,479	24,218,091	23,170,505

Total Encumbered (c)	Budget Remaining (a)-(b)-(c)	% YTD Budget (b)/(a)	% YTD Budget Encumbered (b+c)/(a)
-	499,145	94.12%	94.12%
-	345,184	93.20%	93.20%
-	(824,008)	941.24%	941.24%
-	818	94.62%	94.62%
-	701,685	81.87%	81.87%
-	540,556	0.41%	0.41%
-	85,919	80.77%	80.77%
-	1,349,300	92.72%	92.72%
-	672,590	8.14%	8.14%
-	991,620	30.41%	30.41%
-	(256,807)	104.09%	104.09%
-	-	0.00%	0.00%
-	1,407,403	83.31%	83.31%
-	2,756,702	89.78%	89.78%

Expenses

Administration	1,420,204	147,844	1,280,943	1,514,662
Board of Directors	245,609	11,452	108,787	143,957
District Maintenance	652,945	45,145	506,606	490,763
Electrical Mechanical	3,192,979	120,749	1,599,309	2,179,895
Engineering	1,544,502	259,277	1,282,141	1,184,019
Fisheries	558,824	40,831	431,215	427,942
Human Resources	540,157	15,151	456,108	-
Information Technology	357,071	37,964	311,953	266,840
Management	1,167,433	75,301	854,424	1,133,628
Pipeline	1,692,805	124,990	1,291,521	1,399,735
Recreation - Operations / Maint. / PR / Water Pk	4,302,509	340,735	2,907,331	3,023,564
Retirees	510,395	28,813	338,337	408,392
Safety / Garage	262,109	19,090	215,340	215,874
Utilities Maintenance	885,052	97,352	857,054	730,360
Water Conservation - P/R	687,318	50,853	520,403	617,979
Water Quality- Lab	808,908	48,148	574,840	551,371
Water Treatment	2,013,736	145,355	1,678,199	1,413,775
Total Operating Expenses (f)	20,842,556	1,609,050	15,214,513	15,702,753
Net, Operating gain/(loss) (d-f)	(2,300,564)	114,724	1,978,180	368,538
Net, total gain/(loss) (d+e-f)	6,132,237	2,728,430	9,003,578	7,467,752

39,926	99,335	90.19%	93.01%
-	136,822	44.29%	44.29%
11,622	134,716	77.59%	79.37%
26,567	1,567,103	50.09%	50.92%
219,409	42,952	83.01%	97.22%
-	127,609	77.16%	77.16%
-	84,049	84.44%	84.44%
-	45,118	87.36%	87.36%
10,406	302,603	73.19%	74.08%
63,618	337,667	76.29%	80.05%
14,525	1,380,653	67.57%	67.91%
-	172,058	66.29%	66.29%
6,364	40,405	82.16%	84.58%
6,028	21,970	96.84%	97.52%
900	166,015	75.71%	75.85%
63,887	170,182	71.06%	78.96%
157,091	178,446	83.34%	91.14%
620,343	5,007,701	73.00%	75.97%

Debt Service	Current Budget (a)	Current Period Balance	Year to Date Balance (b)	Prior Year to Date Balance
CFD 2013-1	2,748,438	6,122	2,351,793	2,360,462
Mira Monte	20,038	56	83.77	576
State Water Project	831,058	70,865	1,033,297	2,450
Total Debt Service	3,599,534	77,043	3,385,173	2,363,488

Total Encumbered (c)	Budget Remaining (a)-(b)-(c)	% YTD Budget (b)/(a)	% YTD Budget Encumbered (b+c)/(a)
-	396,645	85.57%	85.57%
-	19,954	0.42%	0.42%
-	(202,239)	124.34%	124.34%
-	214,361	94.04%	94.04%

Capital	Current Budget (a)	Current Period Balance	Year to Date Balance (b) FY2022	Prior Year to Date Balance
Administration	-	-	-	-
Board of Directors	-	-	-	-
District Maintenance	16,000	9,993	19,392	-
Electrical Mechanical	80,900	1,663	28,111	76,917
Engineering	3,350,000	148,145	1,843,170	2,945,653
Engineering- CFD	6,291,000	256,359	2,577,442	-
Fisheries	-	-	-	-
Information Technology	-	-	-	-
Management	-	-	-	-
Pipeline	73,100	-	13,943	16,265
Recreation - Operations / Maint. / PR / Water Pk	227,500	10,847	208,377	4,043
Retirees	-	-	-	-
Safety / Garage	266,914	475	80,415	53,938
Utilities Maintenance	78,200	-	94,582	59,089
Water Conservation - P/R	-	-	-	-
Water Quality- Lab	84,544	-	25,762	24,270
Water Treatment	195,500	9,683	155,415	32,834

Total Encumbered (c)	Budget Remaining (a)-(b)-(c)	% YTD Budget (b)/(a)	% YTD Budget encumbered (b+c)/(a)
-	-	0.00%	0.00%
-	-	0.00%	0.00%
40	(3,432)	121.20%	121.45%
58,663	(5,874)	34.75%	107.26%
2,506,832	(1,000,003)	55.02%	129.85%
6,227,579	(2,514,021)	40.97%	139.96%
-	-	0.00%	0.00%
-	-	0.00%	0.00%
-	-	0.00%	0.00%
27,545	31,613	19.07%	56.75%
2,830	16,293	91.59%	92.84%
-	-	0.00%	0.00%
4,706	181,794	30.13%	31.89%
11,416	(27,798)	120.95%	135.55%
-	-	0.00%	0.00%
14	58,768	30.47%	30.49%
7,254	32,831	79.50%	83.21%

Total Capital 10,663,658 437,166 5,046,608 3,213,010

8,846,880 (3,229,830) 47.33% 130.29%

Robles Forebay Restoration (7/28)	-
Grant Support Services (9/8)	75,000
Robles Forebay Restoration (9/8)	320,475
Robles Diversion Canal Panel Replacement (9/8)	15,000
Mutual Well #7 (9/8)	795,000
LCRA Prefabricated Camping Cabins (TBD)	90,000
CalWEP Smart Rebates Program (9/22)	10,000
Hildebrand Consulting- Water Rate Study (9/22)	79,810
LCRA grant writing services for EDA ARPA Tourism Grant (11/24)	25,048
LCRA Sewer phases 1&2 for EDA ARPA Tourism Grant (11/24)	144,542
LCRA Vegetation Mgt Plan (TBD)	20,000
LCRA Swer Project Enviromental Services (12/8)	75,000
GEOInovo Solutions- Redistricting Servies (1/26)	27,670
San Antonion Well #3 (1/26)	86,745
Rincon Control Tank Structural Eval. (2/9)	40,000
Santa Ana Bridge (2/23)	141,000
Admin Building Rehab (4/28)	300,000
SiteLogicIQ- Energy Conservation Consultant (5/25)	12,500
Bureau of Rec- Robles Diversion (5/25)	20,000
Board Approved unbudgeted items	2,277,790

Net assets, End of year (Total Revenue-Total Expenses-Total Debt Service-Total Capital-Unbudgeted Items) (10,408,745) 2,214,221 571,797 1,891,254

	Beginning of Fiscal Year Balance	Year to Date Balance
General Fund Balance	6,616,588	10,377,488
U.S Bank Investments	11,185,313	9,962,053
U.S Bank Money Market Account	595,084	1,020,685
LAIF	482	483
County of Ventura Investment (COVI)	3,056	3,066
CFD-2013-1 Improvement Bond	11,067,442	7,238,679
Total Reserves	29,467,965	28,602,454

April Summary

- Received our tax revenue from county totaling \$2.6 million. Of that \$1.1 million is for CFD 2013-1, \$1.1 million is related to our 1% allocation, and \$400k related to State Water Project.

- Majority of the capital expenses relate to CFD 2013-1 project Well Rehabilitation and mutual well #7. Other capital expenses matilija pipeline replacement and the masterplan.

CASITAS MUNICIPAL WATER DISTRICT
 REVENUE & EXPENSE REPORT (UNAUDITED)
 AS OF: APRIL 30TH, 2022

11 -GENERAL FUND
 FINANCIAL SUMMARY

% OF YEAR COMPLETED: 83.33

	CURRENT BUDGET	CURRENT PERIOD	YEAR TO DATE BALANCE	PRIOR YEAR YEAR TO DATE	TOTAL ENCUMBERED	TOTAL BALANCE	% YTD BUDGET
<u>REVENUE SUMMARY</u>							
<u>NON DEPARTMENTAL</u>							
WATER SALES	8,492,083	574,316.07	7,992,937.84	7,623,712.41	0.00	499,145.16	94.12
WATER SERVICES	15,218	100.00	14,400.00 (3,862.86)	0.00	818.00	94.62
WATER STANDBY	5,075,845	462,776.71	4,730,661.04	4,200,891.02	0.00	345,183.96	93.20
WATER DELINQUENCY	97,951	101,176.29	921,958.67	1,161,694.32	0.00 (824,007.67)	941.24
WATER REVENUE OTHER	732,162	1,553.99	60,723.32	838,199.02	0.00	671,438.68	8.29
CAPITAL FACILITIES	71,849	0.00	146,089.31	40,588.84	0.00 (74,240.31)	203.33
INTEREST	375,000	25,316.34	214,584.21	278,075.01	0.00	160,415.79	57.22
TAXES & ASSESSMENTS	2,497,277	1,075,412.91	2,611,630.52	2,540,519.71	0.00 (114,353.52)	104.58
OTHER GOVT. AGENCIES	1,440,915	8,045.55	441,804.75	8,527.40	0.00	999,110.25	30.66
MISCELLANEOUS REVENUES	<u>136,311</u>	<u>0.00</u>	<u>143,064.70</u>	<u>149,463.74</u>	<u>0.00 (</u>	<u>6,753.70)</u>	<u>104.95</u>
TOTAL NON DEPARTMENTAL	18,934,611	2,248,697.86	17,277,854.36	16,837,808.61	0.00	1,656,756.64	91.25
<u>RECREATION - OPERATIONS</u>							
RECREATION PARK	3,748,270	535,907.82	3,018,243.36	2,617,719.77	0.00	730,026.64	80.52
RECREATION-CONCESSION	123,000	23,103.65	149,867.62	152,593.75	0.00 (26,867.62)	121.84
RECREATION OTHER	<u>0</u>	<u>150.75</u>	<u>1,473.76</u>	<u>176.99</u>	<u>0.00 (</u>	<u>1,473.76)</u>	<u>0.00</u>
TOTAL RECREATION - OPERATIONS	3,871,270	559,162.22	3,169,584.74	2,770,490.51	0.00	701,685.26	81.87
<u>RECREATION - WATER PARK</u>							
RECREATION-CONCESSION	4,674	0.00	0.00	0.00	0.00	4,674.00	0.00
RECREATION-WATER PARK	<u>538,102</u>	<u>720.00</u>	<u>2,220.00 (</u>	<u>75.00)</u>	<u>0.00</u>	<u>535,882.00</u>	<u>0.41</u>
TOTAL RECREATION - WATER PARK	542,776	720.00	2,220.00 (75.00)	0.00	540,556.00	0.41
TOTAL REVENUES	23,348,657	2,808,580.08	20,449,659.10	19,608,224.12	0.00	0.00	87.58

CASITAS MUNICIPAL WATER DISTRICT
 REVENUE & EXPENSE REPORT (UNAUDITED)
 AS OF: APRIL 30TH, 2022

11 -GENERAL FUND
 FINANCIAL SUMMARY

% OF YEAR COMPLETED: 83.33

	CURRENT BUDGET	CURRENT PERIOD	YEAR TO DATE BALANCE	PRIOR YEAR YEAR TO DATE	TOTAL ENCUMBERED	TOTAL BALANCE	% YTD BUDGET
<u>EXPENDITURE SUMMARY</u>							
<u>RETIREES</u>							
Benefits	510,395	28,812.82	338,337.49	408,392.08	0.00	172,057.06	66.29
TOTAL RETIREES	510,395	28,812.82	338,337.49	408,392.08	0.00	172,057.06	66.29
<u>BOARD OF DIRECTORS</u>							
Salaries	118,812	6,732.68	51,524.90	63,567.06	0.00	67,287.10	43.37
Benefits	116,448	4,485.59	54,371.20	63,534.43	0.00	62,076.60	46.69
Services & Supplies	10,350	234.03	2,891.18	16,855.63	0.00	7,458.82	27.93
TOTAL BOARD OF DIRECTORS	245,610	11,452.30	108,787.28	143,957.12	0.00	136,822.52	44.29
<u>MANAGEMENT</u>							
Salaries	625,588	49,113.65	514,326.58	616,578.93	0.00	111,261.36	82.21
Benefits	181,373	18,301.48	167,260.64	187,624.46	0.00	14,112.10	92.22
Services & Supplies	360,473	7,885.57	172,836.94	329,424.30	10,406.26	177,229.30	50.83
TOTAL MANAGEMENT	1,167,433	75,300.70	854,424.16	1,133,627.69	10,406.26	302,602.76	74.08
<u>HUMAN RESOURCES</u>							
Salaries	141,228	11,406.07	122,335.38	0.00	0.00	18,893.08	86.62
Benefits	33,890	3,700.00	38,098.02	0.00	0.00	(4,208.24)	112.42
Services & Supplies	365,040	44.94	295,674.73	0.00	0.00	69,365.27	81.00
TOTAL HUMAN RESOURCES	540,158	15,151.01	456,108.13	0.00	0.00	84,050.11	84.44
<u>INFORMATION TECHNOLOGY</u>							
Salaries	237,036	18,920.54	197,278.55	179,440.35	0.00	39,757.44	83.23
Benefits	81,542	8,090.05	80,683.20	66,015.74	0.00	858.83	98.95
Services & Supplies	38,493	10,953.44	33,991.04	21,383.99	0.00	4,501.46	88.31
TOTAL INFORMATION TECHNOLOGY	357,071	37,964.03	311,952.79	266,840.08	0.00	45,117.73	87.36
<u>WATER CONSERVATION</u>							
Salaries	393,463	33,685.21	330,909.59	301,562.64	0.00	62,553.29	84.10
Benefits	137,822	13,424.57	132,110.43	128,120.88	0.00	5,711.72	95.86
Services & Supplies	156,032	3,743.67	57,382.70	188,295.08	900.00	97,749.30	37.35
TOTAL WATER CONSERVATION	687,317	50,853.45	520,402.72	617,978.60	900.00	166,014.31	75.85
<u>FISHERIES</u>							
Salaries	391,154	27,430.24	286,359.09	284,110.11	0.00	104,794.45	73.21
Benefits	116,602	11,040.90	112,344.01	106,102.53	0.00	4,257.77	96.35
Services & Supplies	51,068	2,359.49	32,512.25	37,728.87	0.00	18,555.75	63.66
TOTAL FISHERIES	558,823	40,830.63	431,215.35	427,941.51	0.00	127,607.97	77.16
<u>ADMINISTRATION SERVICES</u>							
Salaries	724,752	56,809.35	571,078.63	594,244.70	0.00	153,673.30	78.80
Benefits	240,883	25,452.61	226,959.95	239,009.75	0.00	13,922.69	94.22
Services & Supplies	952,093	64,215.56	470,673.30	666,594.72	39,925.82	441,494.25	53.63
Other Operating Expenses	(523,832)	0.00	0.00	0.00	0.00	(523,831.93)	0.00
TOTAL ADMINISTRATION SERVICES	1,393,896	146,477.52	1,268,711.88	1,499,849.17	39,925.82	85,258.31	93.88

CASITAS MUNICIPAL WATER DISTRICT
 REVENUE & EXPENSE REPORT (UNAUDITED)
 AS OF: APRIL 30TH, 2022

11 -GENERAL FUND
 FINANCIAL SUMMARY

% OF YEAR COMPLETED: 83.33

	CURRENT BUDGET	CURRENT PERIOD	YEAR TO DATE BALANCE	PRIOR YEAR YEAR TO DATE	TOTAL ENCUMBERED	TOTAL BALANCE	% YTD BUDGET
<u>WAREHOUSE</u>							
Salaries	9,971	638.18	6,519.50	0.00	0.00	3,451.50	65.38
Benefits	3,035	176.38	1,717.41	246.23	0.00	1,317.99	56.58
Services & Supplies	13,300	552.21	3,994.60	14,566.14	0.00	9,305.40	30.03
TOTAL WAREHOUSE	26,306	1,366.77	12,231.51	14,812.37	0.00	14,074.89	46.50
<u>GARAGE</u>							
Salaries	25,814	926.41	9,721.97	9,816.36	0.00	16,091.89	37.66
Benefits	10,066	319.79	3,274.41	2,259.24	0.00	6,791.94	32.53
Services & Supplies	38,285	4,384.16	50,862.04	41,953.90	6,364.36 (18,941.40)	149.47
Services & Supplies-W.O.	233,434	0.00	72,620.75	53,938.15	0.00	160,813.25	31.11
TOTAL GARAGE	307,599	5,630.36	136,479.17	107,967.65	6,364.36	164,755.68	46.44
<u>SAFETY</u>							
Salaries	121,420	8,703.66	89,949.22	91,274.28	0.00	31,471.17	74.08
Benefits	48,681	4,471.29	46,101.42	48,310.20	0.00	2,579.52	94.70
Services & Supplies	17,843	284.69	15,430.73	22,259.78	0.00	2,412.27	86.48
Services & Supplies-W.O.	33,480	474.77	7,793.86	0.00	4,705.73	20,980.41	37.33
TOTAL SAFETY	221,424	13,934.41	159,275.23	161,844.26	4,705.73	57,443.37	74.06
<u>ENGINEERING</u>							
Salaries	864,223	46,894.68	507,485.08	559,029.17	0.00	356,737.80	58.72
Benefits	266,007	22,734.84	221,738.69	214,406.50	0.00	44,268.42	83.36
Services & Supplies	414,273	189,647.48	552,917.54	410,583.30	219,408.87 (358,053.91)	186.43
Salaries - Work Orders	0	19,507.90	168,954.58	104,216.11	0.00 (168,954.58)	0.00
Benefits - Work Orders	0	2,479.52	23,294.43	16,867.44	0.00 (23,294.43)	0.00
Services & Supplies-W.O.	9,641,000	382,516.86	4,228,363.10	2,824,569.22	8,734,411.40 (3,321,774.50)	134.45
TOTAL ENGINEERING	11,185,502	663,781.28	5,702,753.42	4,129,671.74	8,953,820.27 (3,471,071.20)	131.03
<u>WATER QUALITY - LAB</u>							
Salaries	349,477	28,843.83	298,310.81	264,457.95	0.00	51,166.36	85.36
Benefits	149,372	13,497.45	136,212.04	131,376.39	0.00	13,159.49	91.19
Services & Supplies	310,061	5,806.38	140,316.74	155,536.51	63,886.52	105,857.43	65.86
Services & Supplies-W.O.	84,544	0.00	25,761.77	24,270.13	14.26	58,768.42	30.49
TOTAL WATER QUALITY - LAB	893,454	48,147.66	600,601.36	575,640.98	63,900.78	228,951.70	74.37
<u>UTILITIES MAINTENANCE</u>							
Salaries	514,179	42,888.02	436,620.52	409,052.98	0.00	77,558.61	84.92
Benefits	189,351	19,084.12	193,781.37	167,075.70	0.00 (4,430.71)	102.34
Services & Supplies	181,522	35,379.54	226,652.58	154,231.51	6,027.51 (51,158.09)	128.18
Services & Supplies-W.O.	78,200	0.00	94,582.04	59,088.95	11,415.69 (27,797.73)	135.55
TOTAL UTILITIES MAINTENANCE	963,252	97,351.68	951,636.51	789,449.14	17,443.20 (5,827.92)	100.61
<u>ELECTRICAL MECHANICAL</u>							
Salaries	711,728	46,977.94	521,924.45	488,221.97	0.00	189,803.66	73.33
Benefits	239,905	19,491.43	219,043.86	207,447.45	0.00	20,861.21	91.30
Services & Supplies	2,241,345	54,279.89	858,340.22	1,484,225.15	26,567.20	1,356,437.58	39.48
Services & Supplies-W.O.	80,900	1,663.18	28,110.59	76,917.16	58,663.42 (5,874.01)	107.26
TOTAL ELECTRICAL MECHANICAL	3,273,878	122,412.44	1,627,419.12	2,256,811.73	85,230.62	1,561,228.44	52.31

CASITAS MUNICIPAL WATER DISTRICT
 REVENUE & EXPENSE REPORT (UNAUDITED)
 AS OF: APRIL 30TH, 2022

11 -GENERAL FUND
 FINANCIAL SUMMARY

% OF YEAR COMPLETED: 83.33

	CURRENT BUDGET	CURRENT PERIOD	YEAR TO DATE BALANCE	PRIOR YEAR YEAR TO DATE	TOTAL ENCUMBERED	TOTAL BALANCE	% YTD BUDGET
<u>DIST MAINT - PIPELINE</u>							
Salaries	676,892	52,807.16	553,788.87	540,776.40	0.00	123,102.76	81.81
Benefits	272,419	23,592.69	242,248.99	256,690.24	0.00	30,169.55	88.93
Services & Supplies	743,495	48,589.89	495,482.79	602,268.28	63,617.55	184,394.16	75.20
Services & Supplies-W.O.	73,100	0.00	13,942.50	16,265.00	27,545.00	31,612.50	56.75
TOTAL DIST MAINT - PIPELINE	1,765,905	124,989.74	1,305,463.15	1,415,999.92	91,162.55	369,278.97	79.09
<u>WATER TREATMENT</u>							
Salaries	860,064	74,362.73	699,136.84	625,914.97	0.00	160,927.02	81.29
Benefits	299,139	34,920.74	342,313.19	298,489.73	0.00	(43,174.17)	114.43
Services & Supplies	854,532	36,071.67	636,749.16	489,370.24	157,091.26	60,691.08	92.90
Services & Supplies-W.O.	195,500	9,683.44	155,414.93	32,834.22	7,254.26	32,830.81	83.21
TOTAL WATER TREATMENT	2,209,234	155,038.58	1,833,614.12	1,446,609.16	164,345.52	211,274.74	90.44
<u>OPERATIONS - MAINTENANCE</u>							
Salaries	280,357	22,076.47	218,384.17	197,261.97	0.00	61,973.19	77.89
Benefits	136,573	11,104.02	111,410.79	120,908.02	0.00	25,162.06	81.58
Services & Supplies	236,016	81,842.17	1,207,203.96	172,592.53	11,622.36	(982,810.32)	516.42
Services & Supplies-W.O.	16,000	9,993.00	19,392.43	0.00	40.00	(3,432.43)	121.45
TOTAL OPERATIONS - MAINTENANCE	668,946	125,015.66	1,556,391.35	490,762.52	11,662.36	(899,107.50)	234.41
<u>GENERAL O&M</u>							
<u>RECREATION - OPERATIONS</u>							
Salaries	1,208,602	89,718.35	941,654.98	1,016,099.42	0.00	266,946.89	77.91
Benefits	393,657	37,101.50	390,790.05	401,727.60	0.00	2,867.15	99.27
Services & Supplies	253,678	20,458.63	197,417.16	198,339.47	8,452.91	47,807.43	81.15
Other Operating Expenses	523,832	0.00	0.00	0.00	0.00	523,831.93	0.00
Salaries - Work Orders	0	0.00	130.48	0.00	0.00	(130.48)	0.00
Benefits - Work Orders	0	0.00	9.98	0.00	0.00	(9.98)	0.00
TOTAL RECREATION - OPERATIONS	2,379,769	147,278.48	1,530,002.65	1,616,166.49	8,452.91	841,312.94	64.65
<u>RECREATION - MAINTENANCE</u>							
Salaries	476,757	41,232.97	394,215.16	411,980.42	0.00	82,541.55	82.69
Benefits	129,332	12,629.22	126,883.59	126,748.02	0.00	2,448.33	98.11
Services & Supplies	424,990	57,228.43	389,801.79	469,428.22	3,070.62	32,117.59	92.44
Services & Supplies-W.O.	137,500	10,836.03	208,110.33	0.00	2,830.00	(73,440.33)	153.41
TOTAL RECREATION - MAINTENANCE	1,168,579	121,926.65	1,119,010.87	1,008,156.66	5,900.62	43,667.14	96.26
<u>RECREATION - PUBLIC REL</u>							
Salaries	208,152	9,864.22	66,139.02	55,668.13	0.00	142,012.56	31.77
Benefits	50,379	2,338.98	19,750.50	7,752.66	0.00	30,628.80	39.20
Services & Supplies	115,550	37,542.42	132,841.51	114,239.19	2,952.00	(20,243.51)	117.52
Services & Supplies-W.O.	0	0.00	0.00	3,998.97	0.00	0.00	0.00
TOTAL RECREATION - PUBLIC REL	374,081	49,745.62	218,731.03	181,658.95	2,952.00	152,397.85	59.26

CASITAS MUNICIPAL WATER DISTRICT
 REVENUE & EXPENSE REPORT (UNAUDITED)
 AS OF: APRIL 30TH, 2022

11 -GENERAL FUND
 FINANCIAL SUMMARY

% OF YEAR COMPLETED: 83.33

	CURRENT BUDGET	CURRENT PERIOD	YEAR TO DATE BALANCE	PRIOR YEAR YEAR TO DATE	TOTAL ENCUMBERED	TOTAL BALANCE	% YTD BUDGET
<u>RECREATION - WATER PARK</u>							
Salaries	376,540	23,519.79	141,445.23	135,889.32	0.00	235,094.49	37.56
Benefits	76,539	6,207.63	64,118.89	50,469.78	0.00	12,420.12	83.77
Services & Supplies	64,502	2,904.06	42,400.24	35,266.21	49.46	22,051.80	65.81
Services & Supplies-W.O.	<u>90,000</u>	<u>0.00</u>	<u>0.00</u>	<u>0.00</u>	<u>0.00</u>	<u>90,000.00</u>	<u>0.00</u>
TOTAL RECREATION - WATER PARK	607,580	32,631.48	247,964.36	221,625.31	49.46	359,566.41	40.82
<hr/>							
TOTAL EXPENDITURES	31,506,212	2,116,093.27	21,291,513.65	18,915,763.13	9,467,222.46	747,476.28	97.63
REVENUE OVER/(UNDER) EXPENDITURES	(8,157,555)	692,486.81	(841,854.55)	692,460.99	(9,467,222.46)	(747,476.28)	126.37

CASITAS MUNICIPAL WATER DISTRICT
 REVENUE & EXPENSE REPORT (UNAUDITED)
 AS OF: APRIL 30TH, 2022

11 -GENERAL FUND
 FINANCIAL SUMMARY

% OF YEAR COMPLETED: 83.33

	CURRENT BUDGET	CURRENT PERIOD	YEAR TO DATE BALANCE	PRIOR YEAR YEAR TO DATE	TOTAL ENCUMBERED	TOTAL BALANCE	% YTD BUDGET
<u>SUMMARY OF EXPENSES</u>							
SALARIES	9,038,396	686,226.26	6,919,997.43	6,840,694.42	0.00	2,118,398.59	76.56
BENEFITS	3,681,171	293,149.74	3,010,243.55	2,972,173.44	0.00	670,927.15	81.77
SERVICES & SUPPLIES	8,122,987	699,562.57	6,314,790.90	5,889,929.92	620,342.70	1,187,853.62	85.38
SALARIES-WORK ORDERS	0	19,507.90	169,085.06	104,216.11	0.00 (169,085.06)	0.00
BENEFITS-WORK ORDERS	0	2,479.52	23,304.41	16,867.44	0.00 (23,304.41)	0.00
SERVICES & SUPPLIES - W.O.	10,663,658	415,167.28	4,854,092.30	3,091,881.80	8,846,879.76 (3,037,313.61)	128.48
TOTAL EXPENDITURES	31,506,212	2,116,093.27	21,291,513.65	18,915,763.13	9,467,222.46	747,476.28	97.63

**CASITAS MUNICIPAL WATER DISTRICT
TREASURER'S MONTHLY REPORT OF INVESTMENTS
06/30/22**

Type of Invest	Institution	CUSIP	Date of Maturity	Original Cost	Current Mkt Value	Rate of Interest	Date of Deposit	% of Portfolio	Days to Maturity
*TB	Federal Home Loan Bank	3130AIXJ2	6/14/2024	\$941,144	\$841,966	2.875%	8/2/2016	8.49%	704
*TB	Federal Home Loan Bank	3130A5VVW6	7/10/2025	\$1,025,110	\$989,060	2.700%	5/10/2017	9.98%	1090
*TB	Federal National Assn	31315P2J7	5/1/2024	\$809,970	\$729,325	3.300%	5/25/2016	7.36%	661
*TB	Farmer MAC	31315PYF0	5/2/2028	\$512,355	\$489,685	2.925%	11/20/2017	4.94%	2102
*TB	Federal Farm CR Bank	31331VWN2	4/13/2026	\$940,311	\$773,716	5.400%	5/9/2016	7.81%	1363
*TB	Federal Home Loan Bank	313383YJ4	9/8/2023	\$476,582	\$417,004	3.375%	7/14/2016	4.21%	428
*TB	Farmer MAC	3133EEPH7	2/12/2029	\$480,251	\$463,564	2.710%	11/20/2017	4.68%	2382
*TB	Federal National Assn	3135G0K36	4/24/2026	\$2,532,940	\$2,414,250	2.125%	7/6/2010	24.36%	1374
*TB	Federal National Assn	3135G0ZR7	9/6/2024	\$1,488,050	\$1,382,082	2.625%	5/25/2016	13.94%	786
*TB	US Treasury Note	912828WE6	11/15/2023	\$723,061	\$662,998	2.750%	12/13/2013	6.69%	495
*TB	US Treasury Note	912796L64	8/11/2022	\$749,187	\$748,898	0.150%	12/31/2021	7.56%	41
Total in Gov't Sec. (11-00-1055-00&1065)				\$10,678,962	\$9,912,550			99.96%	
Total Certificates of Deposit:				\$0	\$0			0.00%	
**	LAIF as of 6/30/2021: (11-00-1050-00)		N/A	\$483	\$483	1.36%	Estimated	0.00%	
***	COVI as of 6/30/2021: (11-00-1060-00)		N/A	\$3,066	\$3,066	1.50%	Estimated	0.03%	
TOTAL FUNDS INVESTED				\$10,682,511	\$9,916,099			100.00%	
Total Funds Invested last report				\$10,682,511	\$10,007,891				
Total Funds Invested 1 Yr. Ago				\$11,755,768	\$11,188,852				
****	CASH IN BANK (11-00-1000-00) EST.			\$7,389,328	\$7,389,328				
	CASH IN Custody Money Market			\$986,964	\$986,964	0.30%			
TOTAL CASH & INVESTMENTS				\$19,058,803	\$18,292,391				
TOTAL CASH & INVESTMENTS 1 YR AGO				\$18,320,954	\$18,400,524				

- *CD CD - Certificate of Deposit
- *TB TB - Federal Treasury Bonds or Bills
- ** Local Agency Investment Fund
- *** County of Ventura Investment Fund
- Estimated interest rate, actual not due at present time.
- **** Cash in bank

No investments were made pursuant to subdivision (i) of Section 53601, Section 53601.1 and subdivision (i) Section 53635 of the Government Code.
All investments were made in accordance with the Treasurer's annual statement of investment policy.